

Contents

Ref.	Description	Length (mm)	Width (mm)	Height (mm)
1	C-frame press	395	95	295
2	Force screw	250	–	–
Ref.	Description	Internal Ø (mm)	External Ø (mm)	Depth (mm)
3	Receiving sleeve	70	76	57
4	Receiving sleeve	57	63	44
5	Receiving sleeve	44	50	44
6	Installation adaptor	24	76	28
7	Removal adaptor	12	76	30
8	Installation tube	44	57	93
9	Receiving tube	50	57	38
10	Installer adaptor	48	60	21



Maintenance

Regular inspection, maintenance and cleaning procedures are highly recommended for safe use

- Before each use, inspect all parts for damage
 - Check for misalignment or binding of moving parts or any other condition that could affect safe operation
 - Do not use damaged parts
- Use high quality and lightweight machine oil to lubricate threads of forcing screw
 - Maintenance and lubrication will prevent binding of the threads under heavy load
- After use, wipe down with damp cloth with mild detergent or solvent, always store in case

TRIDON

TOLEDO IS A REGISTERED
TRIDON BRAND

311019 MAN © Copyright TRIDON AUSTRALIA PTY. LTD. 2020

A.C.N. 001 398 698 Reproduction of this manual in part or full is not permitted without written approval. Illustrations in this manual are for identification purposes only and there may be slight variations between the illustration and actual product. Whilst every effort has been made to ensure that the information contained in this catalogue is accurate at the time of printing, TRIDON AUSTRALIA PTY LTD will not accept responsibility should any inaccuracies be contained herein.

FAMOUS
TOLEDO
EXCELLENCE BY DESIGN

FAMOUS
TOLEDO
EXCELLENCE BY DESIGN

Ball Joint C-Frame Press Kit User Guide



- The purpose of this tool is to remove and install ball joints, brake anchor pins and U joints
- Universal tool applicable for AWD, FWD & RWD passenger and light commercial vehicles
- Includes various size sleeves and adaptors
- Manufactured from heavy duty forged steel for strength and durability

10 Piece

Important

- **WARNING!** Ensure all health and safety, local authority and general workshop practice regulations are adhered to when using these tools.
- **DO NOT** use tools if seals or threads are damaged. This may incur false readings and personal injury.
- Any defective seals **MUST** be replaced before use to avoid incorrect readings.
- Maintain the tools in good, clean condition for optimum performance.
- Ensure that a vehicle that has been jacked up is adequately supported with axle stands.
- Wear approved eye protection.
- Wear suitable clothing to avoid snagging, tie back long hair and **DO NOT** wear jewellery.
- Ensure fuel supply is isolated to prevent fire whilst engine is being tested.
- Ensure that the correct connector is used for the engine/vehicle being tested.
- Always release the pressure from the gauge before disconnecting the quick release coupling.
- Account for all tools and parts being used and **DO NOT** leave them in or near the engine.
- **WARNING!** Select neutral or 'park' if automatic transmission and keep hands clear of the rotating engine.
- **IMPORTANT:** Always refer to the vehicle manufacturer's workshop manual, or a proprietary manual, to establish the current procedure and data.
- These instructions are provided as a guide only.
- When not in use, return all parts in the supplied case and store this in a safe, dry, childproof location.
- **WARNING!** The warnings, cautions and instructions referred to in this manual cannot cover all possible conditions and situations that may occur.
- It must be understood that common sense and caution are factors which cannot be built into this product, but must be applied by the operator.

Instructions

Before use

- Ensure forcing screw threads are clean and lubricated
- Check all sleeves and adaptors are in serviceable condition
- It is recommended to apply penetrating oil on corroded ball joints
- Always refer to the manufacturer's workshop manual for correct procedure and tightening specifications
- Secure vehicle to prevent personal injury
- Ensure personal protection equipment is used at all times, such as gloves and eye protection
- It is highly recommended to be hand wound only

How to remove ball joint

1. Assemble the C-frame press over the vehicle's control arm as shown in **Figure A**. Select the correct size receiving sleeve, and position it under the vehicle's ball joint
2. Begin to tighten the forcing screw until the receiving sleeve contacts the vehicle's control arm
3. Check the alignment of all tooling and components, and continue tightening the forcing screw until the vehicle's ball joint is removed

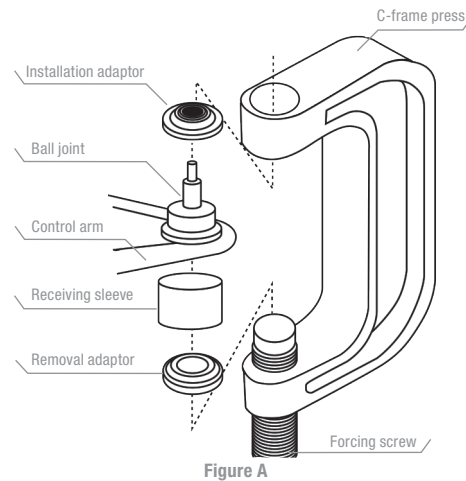

How to install ball joint

1. Clean the vehicle's control arm where the ball joint will sit and lightly coat the inside surface of the control arm with suitable lubricant
2. Align the new ball joint as straight as possible
3. Assemble the C-frame press as shown in **Figure B** over the vehicle's control arm. Position the receiving sleeve and tighten the forcing screw. Check the alignment of all tooling and components and continue tightening until ball joint is firmly seated

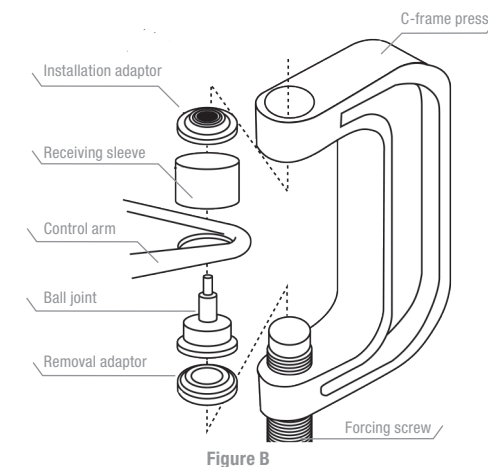

How to remove and install brake anchor pins

1. To remove the brake anchor pins, remove all lock ring retainers from the brake anchor pins
2. Position the ball joint press over the brake spider as shown in **Figure C**
3. Tighten the forcing screw until the anchor pins can be removed
4. To install insert the brake anchor pins, then reinstall the lock ring retainers

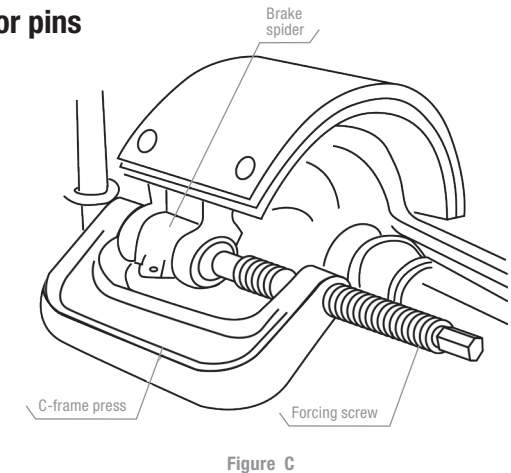

How to disassemble/assemble U joint

1. To disassemble a "U" joint, remove any external and/or internal lock rings
2. Position the C-frame press around the drive shaft yoke and tighten the forcing screw until the first bearing is removed as shown in **Figure D**
3. Reposition the C-frame press and remove the second bearing
4. To assemble the "U" joint, thoroughly clean all dirt and oil from the yoke area
5. Align the replacement bearing and C-frame press as straight as possible over the yoke. Press the replacement bearing into the yoke and reassemble the lock rings
6. Reposition the C-frame press on second bearing and repeat step 5

