

245380

FAMOUS  
**TOLEDO**  
EXCELLENCE BY DESIGN

# Power Steering Pump Kit Removal & Installation User Guide

- For quick and easy removal and installation of power steering pump pulleys
- Prevents pulley and shaft from distortion
- Suitable for use ON and OFF vehicle
- Pulley removal, installer and coupler disconnect tool included
- Applications include Ford Falcon FG, Ford C111, Saginaw, Thompson, C2 power steering pumps



## Warning

- **WARNING!** Ensure all Health and Safety, local authority and general workshop practice regulations are adhered to when using these tools
- **DO NOT** use tools if threads are damaged
- Any defective tools **MUST** be replaced before use
- Maintain the tools in a good, clean condition for optimum performance
- Ensure that a vehicle that has been jacked up is adequately supported with axle stands
- Wear approved eye protection
- Wear suitable clothing to avoid snagging, tie back long hair and **DO NOT** wear jewellery
- Account for all tools, and parts being used and **DO NOT** leave them in or near the engine
- **WARNING!** Select neutral or 'park' if automatic transmission and keep hands clear of the rotating engine
- **IMPORTANT:** Always refer to the vehicle manufacturer's workshop manual, or a proprietary manual, to establish the current procedure and data
- These instructions are provided as a guide only
- When not in use, return all parts in the supplied case and store this in a safe, dry, childproof location
- **WARNING!** The warnings, cautions and instructions referred to in this manual cannot cover all possible conditions and situations that may occur. It must be understood that common sense and caution are factors which cannot be built into this product, but must be applied by the operator

## Instruction

### REMOVAL

**NOTE:** Always inspect and lubricate threaded parts before using tool to ensure smooth operation

1. Select correct forcing screw for removal
2. Place jaw enclosure to the pulley and around the pulling flange
3. Place retaining ring over the puller jaws to secure them
4. Using a wrench tighten the forcing screw while holding the pulling flange nut. This will draw the pulley off the shaft

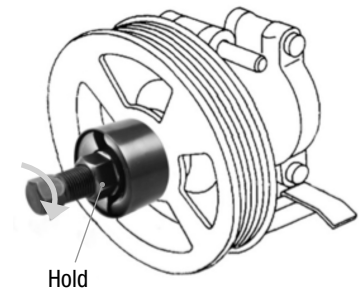

### INSTALLATION

1. Select correct forcing screw for installation
2. Place pulley over shaft
3. Ensure threaded screw is entirely through the centre hole of the shaft
4. Using a wrench slowly wind in the flange nut sleeve, forcing the pulley on to the shaft

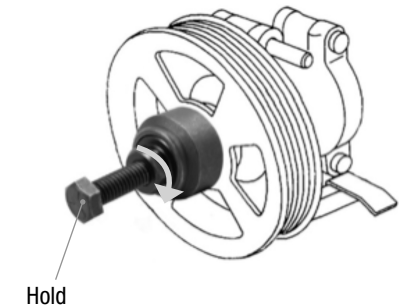

FAMOUS  
**TOLEDO**  
EXCELLENCE BY DESIGN

**TRIDON** ▶  
TOLEDO IS A REGISTERED  
TRIDON BRAND

245380 MAN © Copyright TRIDON AUSTRALIA PTY. LTD. 2017  
A.C.N. 001 398 698 Reproduction of this manual in part or full is not permitted without written approval. Illustrations in this manual are for identification purposes only and there may be slight variations between the illustration and actual product. Whilst every effort has been made to ensure that the information contained in this catalogue is accurate at the time of printing, TRIDON AUSTRALIA PTY LTD will not accept responsibility should any inaccuracies be contained herein.