

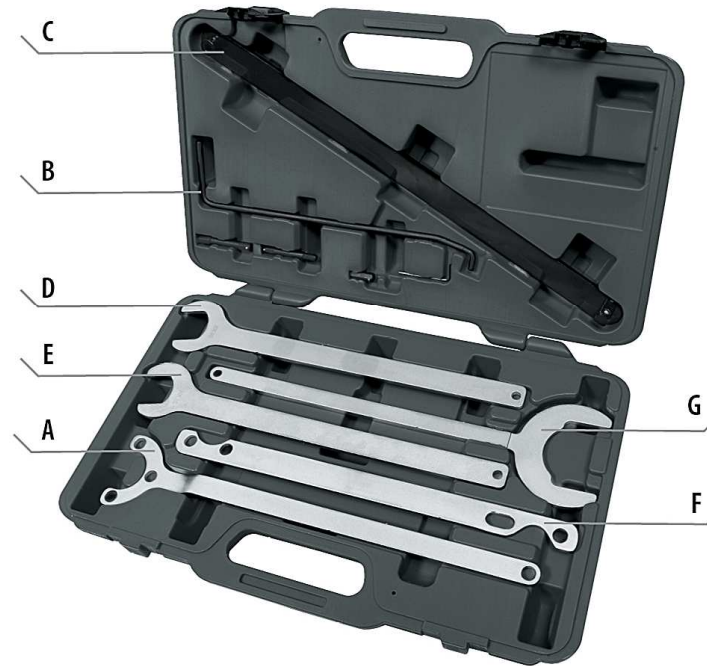

FAN CLUTCH SPANNER SET MASTER



CONTENTS

Ref. code	Description	Application	Size	Overall Length
A	Hub securing bar (Mercedes OEM Part no. 113-0040)	Mercedes-Benz Engines: M111, M112, M113, M119	Ø 65mm	410mm
B	Fan removing tool Hex 8mm (Mercedes OEM Part no. 104 589 00 01 00)	Mercedes-Benz: 300E (1985 - 1992), 260E (1987 - 1990), 300CE (1988 - 1989), 300TE (1988 - 1991), 300E 2.6 (1990 - 1992), 300TE 24 (1990 - 1993), 300CE 24 (1990 - 1993), 300E 24 (1990 - 1993), 300CE (1993 - 1994), 280E (1993 - 1994), 300E 2.8 (1993 - 1994), E280 (1994 - 1996), 320TE (1993 - 1994), E320 (1994 - 1996)	8mm	300mm
C	Wrench/Holding Bar with adaptor sizes: 6, 8, 10mm Hex (10mm hex used for adjusting A/C belt tension and removing idler pulley on 420 & 560 models with V8 from 1986)	Mercedes-Benz Engines: M130, M104, M111, M119, M120, OM602, OM603, OM605, OM606	6, 8, 10mm	490mm
D	Open end wrench 32mm	BMW Engines: M10, M10, M20, M40, M41, M42, M50, M60, M62, FORD: 6 Cylinder	Ø 32mm	375mm
E	Open end wrench 36mm	GM, FORD: 8 Cylinder	Ø 36mm	375mm
F	Water pump holding tool	BMW Engines: M10, M20, M40, M41, M42, M44, M50, M52, M52TU, M54, M56, M60, M62, M70, M73, S14, S38, S50B30, S50B32, S54, S62B50	45 x 60mm	380mm
G	Hub holding wrench	Universal open-end wrench to remove the thermofan clutch from most BMW & Mercedes-Benz. Suitable for fan-clutch replacement, water-pump service and other front-engine repair work. Opening width 65mm, opening length 40mm and thickness 5mm.	Ø 65mm	390mm