

MATSON



PRODUCT CATALOGUE



Founded in Australia in 1947, Matson is a leading name in the manufacture and supply of quality battery related products.

Trusted by professionals and weekend warriors alike, Matson products are recognised for their high quality, extensive range and innovative product development. Originally a world leader in the development and manufacture of brass battery terminals and jumper cables, Matson now also boasts an extensive range of battery chargers, power inverters, jump starting equipment, battery monitoring and testing equipment, solar solutions and an extensive range of battery accessories.

The Matson range is constantly growing, bringing our customers new and innovative products that are designed to make the task easier, faster and safer.

Matson is a registered brand of Tridon Australia, a proud Australian family owned company with a diverse array of brands supporting the Australian automotive and industrial markets. With warehouses and representation servicing all states and territories, Tridon prides itself on exceptional customer service and its ability to have the right part in the right place for all customer requirements.

For further information, please contact Tridon customer service on **1300 362 263** or visit **tridon.com.au**



**SETTING THE STANDARD
SINCE 1947**

CONTENTS

CHARGING	12 Volt	4
	Multi Volt	7
	DC-DC	9
	Battery Boxes	11
	Solar	12
SYSTEM MONITORING	Vehicle	14
	Batteries	15
BATTERY TESTING	Digital	17
JUMP STARTING	Lithium	20
	Lead Acid	23
	Jumper Leads	26
	Surge Protection	27
MEMORY SAVER	12 Volt	28
POWER INVERTERS	Pure Sine	29
CABLES	Finished Cables	32
	Accessory Cables	33
TERMINALS	Battery Terminals	34
	Accessories	37
	Crimp Lugs	39
BULK CABLES	Rolls	40
ACCESSORIES	Crimping Tools	41
	Switches	42
	Miscellaneous	43
INDEX		45

AUTOMATIC BATTERY CHARGERS

SAFE

Non-sparking, short circuit and reverse-polarity protected for peace of mind operation

SIMPLE

One-step operation. Simply connect the charger to the battery, turn on mains power and charging will begin immediately

FULLY AUTOMATIC

Fully automatic charging and maintenance to maximise battery life and performance



POWERED BY **DHC**



AE120E 12V BATTERY CHARGER 1.2 AMP

- One step operation
- Fully automatic charging
- Maintains optimum battery condition
- Ideal for all lead acid batteries
- Automatic maintenance mode



SPECIFICATIONS	
Input Voltage	240VAC, 50 Hz
Charging Current	1.2 Amps
Weight	0.38kg
Dimensions	135 x 75 x 50mm
Charging Voltage	14.8V
Min. Start Voltage	1V
Charger Type	5 stage, Automatic charging cycle
Battery Type	Flooded, AGM and Deep Cycle
CCA	100 - 600
AMP Hours	Up to 25Ah
Protection	Reverse polarity, over temperature, over current, short circuit, spark free protection

AE120E Charging Time Guide						
100CCA			120CCA			
6 hours			7 hours			
200CCA	300CCA	400CCA	500CCA	600CCA	750CCA	
Maintenance						



AE150E 12V BATTERY CHARGER 1.5 AMP

- LED display with battery status indicators
- Microprocessor controlled
- Smart Pulse Technology
- Maintenance capabilities
- Inbuilt safety protections
- Replacement charging lead – Part No: AE500E-1
- Spare 12V Cig plug lead – Part No: AECIG



SPECIFICATIONS	
Input Voltage	220 - 240VAC, 50 Hz
Charging Current	1.5A
Weight	0.46kg
Dimensions	170 x 73 x 48mm
Charging Voltage	12 - 14.8V
Min. Start Voltage	1V
Charger Type	5 stage, Automatic charging cycle
Battery Type	Flooded, AGM and Deep Cycle
CCA	100 - 750
AMP Hours	Up to 30Ah
Protection	Reverse polarity, over temperature, over current, short circuit, spark free protection

AE150E Charging Time Guide						
100CCA			120CCA			
5 hours			6 hours			
200CCA	300CCA	400CCA	500CCA	600CCA	750CCA	
Maintenance						



AE300E 12V BATTERY CHARGER 3 AMP

- LED display with battery status indicators
- Microprocessor controlled
- Smart Pulse Technology
- Maintenance capabilities
- Inbuilt safety protections
- Replacement charging lead – Part No: AE500E-1
- Spare 12V Cig plug lead – Part No: AECIG



SPECIFICATIONS			
Input Voltage	220 - 240VAC, 50 Hz		
Charging Current	3.0A		
Weight	0.46kg		
Dimensions	170 x 73 x 48mm		
Charging Voltage	12 - 14.8V		
Min. Start Voltage	1V		
Charger Type	5 stage, Automatic charging cycle		
Battery Type	Flooded, AGM and Deep Cycle		
CCA	100 - 750		
AMP Hours	Up to 60Ah		
Protection	Reverse polarity, over temperature, over current, short circuit, spark free protection		

AE300E Charging Time Guide			
100CCA	120CCA	200CCA	300CCA
3 hours	3.5 hours	6 hours	8 hours
400CCA	500CCA	600CCA	750CCA
11 hours	15 hours	18 hours	23 hours



AE500E 12V BATTERY CHARGER 5 AMP

- LED display with battery status indicators
- Microprocessor controlled
- Smart Pulse Technology
- Maintenance capabilities
- Inbuilt safety protections
- Replacement charging lead – Part No: AE500E-1
- Spare 12V Cig plug lead – Part No: AECIG



SPECIFICATIONS	
Input Voltage	220 - 240VAC, 50 Hz
Charging Current	5.0A
Weight	0.51kg
Dimensions	170 x 73 x 48mm
Charging Voltage	12 - 14.8V
Min. Start Voltage	1V
Charger Type	5 stage, Automatic charging cycle
Battery Type	Flooded, AGM and Deep Cycle
CCA	100 - 750
AMP Hours	Up to 100Ah
Protection	Reverse polarity, over temperature, over current, short circuit, spark free protection

AE500E Charging Time Guide			
100CCA	120CCA	200CCA	300CCA
Not recommended	Not recommended	3.5 hours	6 hours
400CCA	500CCA	600CCA	750CCA
7.5 hours	10 hours	12 hours	15 hours



AE1000E 12V BATTERY CHARGER & POWER SUPPLY

- IP65 waterproof and dustproof
- Large LED screen display
- Chemistry selectable including Lithium (LiFePO4)
- Power supply function
- Microprocessor controlled
- Smart Pulse Technology
- Maintenance capabilities
- Full safety protections
- Replacement charging lead – Part No: AE500E-1
- Spare 12V Cig plug lead – Part No: AECIG



SPECIFICATIONS	
Input Voltage	220 - 240VAC, 50 Hz
Charging Current	2.0A - 10.0A
Weight	0.88kg
Dimensions	210 x 98 x 60mm
Charging Voltage	Variable by chemistry
Min. Start Voltage	2V
Charger Type	Lead Acid - 9 stage & Lithium - 6 stage
Battery Type	12V Flooded, AGM Sealed, Gel, Calcium and Lithium (LiFePO4)
Power Supply Mode	13.6 Volt 10 Amp
CCA	Up to 1000CCA
AMP Hours	Up to 150Ah
Protection	Reverse polarity, over temperature, over current, short circuit, spark free protection

AE1000E Charging Time Guide			
100CCA	120CCA	200CCA	300CCA
3.5 hours	4 hours	3 hours	4 hours
400CCA	500CCA	600CCA	750CCA
5 hours	7.5 hours	9 hours	11 hours



SCM54E 12V 4 STATION BATTERY CHARGER

- LED display
- Four independent charging stations
- Replacement cable set – Part No: SCM54E-CS



SPECIFICATIONS

Charging Stage	5 Stage
Input	240VAC, 50Hz
Output Voltage	12 Volt DC
Output Current	5A x 4
Min. Start Voltage	1.5 Volt
Desulphation	Yes
Soft Start	Yes
Charge Rate	14.8V
Absorption	Yes
Equalisation	Yes
Analysis/Fault Find	Yes
Recondition	Yes
Float	13.7V
Case Construction	ABS + PC Plastic
Fan Cooled	Yes
Weight	2.5kg
Dimensions	350 x 190 x 75mm
Permanent Mount	Yes
Size	10 - 200 AH
Battery Type	Deep Cycle and Automotive VRLA / AGM / SLA / Flooded & Lead Acid





MA4INONE 12/24/36/48V BATTERY CHARGER

- Four different voltage settings
- Fully automatic switch mode charging and maintenance capabilities
- Offers protection against short circuiting, reverse connection and overheating
- LED display bar indicates what voltage has been selected and percentage charged
- Charges lead acid, NIMH, AGM and sealed batteries
- Heavy duty aluminium housing



SPECIFICATIONS	
Charging Stage	3 Stage
Input	240VAC
Output Voltage	12/24/36/48 Volt DC
Output Current	30/25/15 Amp
Min. Start Voltage	Refer to CHARGE OUTPUT table
Desulphation	Yes
Soft Start	Yes
Charge Rates	Refer to CHARGE OUTPUT table
Absorption	Yes
Equalisation	Yes
Analysis/Fault Find	Yes
Recondition	Yes
IP Rating	N/A
Case Construction	Aluminium
Fan Cooled	YES
Weight	5kg
Dimensions	300 x 223 x 101mm
Permanent Mount	YES
Size	10 - 400Ah
Battery Type	Deep Cycle and Automotive VRLA / AGM / SLA / Flooded & Lead Acid



	CHARGE OUTPUT			
Nominal Output Voltage	12V	24V	36V	48V
Max Output A	30A	30A	25A	15A
Max Output Power	450W	900W	1000W	900W
Charge Voltage	14.7V	29.4V	44.1V	58.8V
Float Voltage	13.6V	26.6V	39.9V	53.2V
Minimum Start Voltage	8.0V	16.0V	27.0V	40.0V



The IR61224 is your ultimate battery management device. With the simplicity of push button selection, the user has full control over the charging of their battery. Change the amperage, voltage and battery chemistry with a simple touch of a button!

For peace of mind, this charger will automatically adjust its output amperage to ensure the battery is protected from overcharging.

The IR61224 has a microprocessor controlled 7 stage charging program. At the completion of each stage, the charger will conduct a diagnosis of the batteries condition to ensure it has been completed correctly. This feature both extends battery life and maximises the usable energy.

IR61224
6/12/24 VOLT CHARGER

- 2, 10 or 20 Amp selectable on 6/12 volt and 5, 2 or 10 Amp selectable on 24 volt
- Electronic touch button control
- Chemistry selectable: GEL, Flooded (SLA, Deep Cycle, AGM), Calcium
- LED Display shows voltage, current (Amps), battery capacity and fault diagnosis
- 7 stage charging for optimum battery conditioning and extended battery life



SPECIFICATIONS	
Charging Stage	7 Stage
Input	240VAC, 50Hz
Output Voltage	6/12/24 Volt DC Selectable
Output Current	6/12 Volt, 2/10/20 Amp. 24 Volt, 2/5/10 Amp. Selectable.
Min. Start Voltage	1.5 Volt
Desulphation	High Frequency Pulse Charge (DEPENDENT ON DIAGNOSIS)
Soft Start	Yes
Charge Rates	6V - (Gel 7.05V) (Flooded/AGM 7.2V)
	12V - (Gel 14.1V) (Flooded/AGM 14.7V) (Calcium 15.1V)
	24V - (Flooded/AGM 28.6V)
Absorption	Yes
Equalisation	Yes
Analysis / Fault Find	Yes
Recondition	Yes
Alternator Function	Alternator Test
Float/Maintain	Yes
Case Construction	Aluminium
Fan Cooled	Yes
Weight	2.4kg
Dimensions	246 x 146 x 50mm
Permanent Mount	No
Warranty	12 Months
Battery Size	2 - 300 Ah Charge & 2 - 400 Ah Maintain
Battery Type	GEL, Flooded, SLA, Deep-Cycle, AGM, Calcium



	DESULPHATION	SOFT START	BULK CHARGE	ABSORPTION	BATTERY TEST	RECONDITION	FLOAT AND PULSE
7 Stage Charging	Reducing the lightly formed sulphate. High frequency pulse charge (Dependent on diagnosis)	Preliminary charge	Rapid Charge 14.1V (Gel), 14.7V (Flooded), 15.1V (Calcium)	Finishing charge. Constant voltage with Amperage control	Analyses the battery state of charge. Automatically detects faulty batteries. Error code signifies fault.	Restores badly discharged battery back to health if possible. Constant current automatically varied	Maintaining charge
Voltage							
Current (Amps)							



MA21DCS 20AMP DC-DC CHARGER WITH SOLAR INPUT

- 20 Amp charging
- Chemistry selectable
- MPPT charging profile
- Dual input - alternator/solar
- IP65 under-bonnet suitable
- Suits smart and conventional alternators



Factory Pre-Fit Connectors

Spare Included

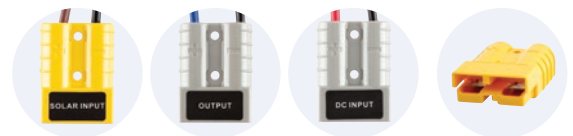

SPECIFICATIONS

Charge Type	Multi-Stage
Input Voltage (V)DC	Battery/DC Input 10.8 - 16.0 Solar 13.5 - 25.0
Cut in/out Voltage with Ignition lead (V)DC	11.5 - 10.8
Cut in/out Voltage NO Ignition lead (V)DC	13.0 - 12.4
Output Current (A)	20
Minimum Start Voltage (V)DC	2
Soft Start Charging	Yes

BULK CHARGE VOLTAGES (V)DC

Gel	14.3	LiFePO	14.4	Suits battery capacity (AH)	18 - 250	Max operating temp (Deg C)	70
AGM/Lead Acid	14.7	Float Charge Voltage (V)DC	13.5	Case Construction	Aluminium	Weight (kg)	1
Calcium	15.3	Float Charge Current (mA)	100	Ingress protection (IP) rating	IP65	Dimensions (mm)	135 x 207 x 37



MA40DCS 40AMP DC-DC CHARGER WITH SOLAR INPUT

- 40 Amp charging
- Chemistry selectable
- Dual input alternator/solar
- IP65 under-bonnet suitable
- Suits smart and conventional alternators
- MPPT solar charge controller



Factory Pre-Fit Connectors

Spare Included

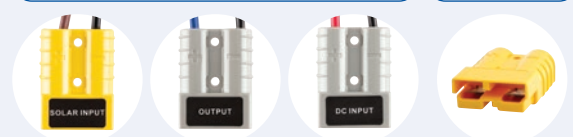

SPECIFICATIONS

Charge Type	Multi-Stage
Input Voltage (V)DC	Battery/DC Input 10.8 - 16.0 Solar 13.5 - 25.0
Cut in/out Voltage with Ignition lead (V)DC	11.5 - 10.8
Cut in/out Voltage NO Ignition lead (V)DC	13.0 - 12.4
Output Current (A)	40
Minimum Start Voltage (V)DC	2
Soft Start Charging	Yes

BULK CHARGE VOLTAGES (V)DC

Gel	14.3	LiFePO	14.4	Suits battery capacity (AH)	40 - 400	Max operating temp (Deg C)	70
AGM/Lead Acid	14.7	Float Charge Voltage (V)DC	13.5	Case Construction	Aluminium	Weight (kg)	1
Calcium	15.3	Float Charge Current (mA)	100	Ingress protection (IP) rating	IP65	Dimensions (mm)	135 x 207 x 37



MA98504
LOW VOLTAGE DUAL BATTERY KIT WITH PARALLEL SWITCH

- Automatically isolates the starting battery from the auxiliary battery
- Suitable for 4X4, marine, truck, caravan and camping applications
- No need to modify vehicle wiring
- Kit contains all components required to complete the job
- Voltage sensitive relay rated at 140 Amps
- Proven reliability over many years
- Easy to install



The Matson Dual Battery Kit is designed to allow the 4WD, caravan and boating enthusiast to run a second battery for all those power hungry outdoor accessories, without risking power drain from the vehicle's starting battery. When installed in accordance with directions, the voltage sensitive relay will stay open when the engine is started, isolating the starting battery, until the charge rate reaches 13.3 Volts at which time the voltage sensitive relay closes allowing both batteries to be charged. When the voltage of the cranking battery drops to 12.8 Volts the relay isolates the two batteries leaving the cranking battery fully charged while the auxiliary battery continues to power the accessories.

The next time the vehicle's engine is running, the starting battery is charged back up to 13.3 Volts, at which time the VSR redirects the charge back to the auxiliary battery.

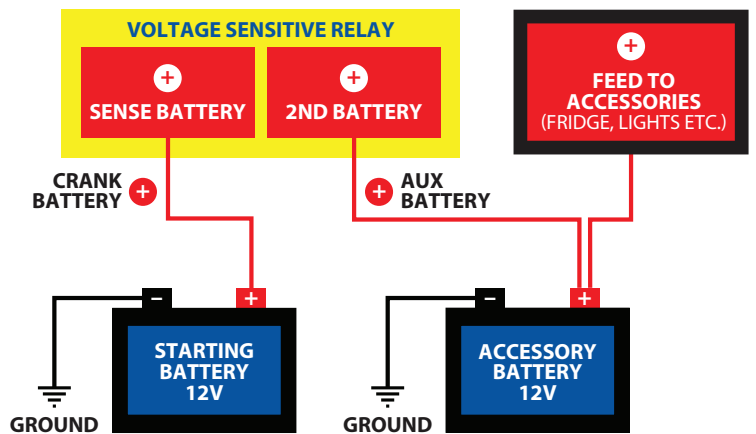

The VSR (voltage sensitive relay) allows two batteries to be charged at the same time and then isolates them from each other when the vehicle is turned off.

The relay stays open, isolating the two batteries when the engine is first started, remaining open until the primary battery has reached a preset voltage of 13.3V. The relay then closes, allowing the two batteries to be charged together. When the engine is stopped, the voltage returns to normal levels allowing the relay to open again. This separates the two batteries and eliminates the possibility of discharging the primary/starting battery.



MA98404
VOLTAGE SENSITIVE RELAY

- 140A continuous current
- Cut-in 13.3V
- Cut-out 12.8V
- Sealed unit - under-bonnet friendly
- Emergency parallel switch





MA98115 BATTERY BOX SMALL

- Internal dimensions: 270 x 180 x 195 (LxWxH mm)
- Tough polypropylene plastic battery box impervious to battery acid
- Complete with tie down strap and mounting hardware



MA98116 BATTERY BOX MEDIUM

- Internal dimensions: 320 x 180 x 195 (LxWxH mm)
- Tough polypropylene plastic battery box impervious to battery acid
- Complete with tie down strap and mounting hardware

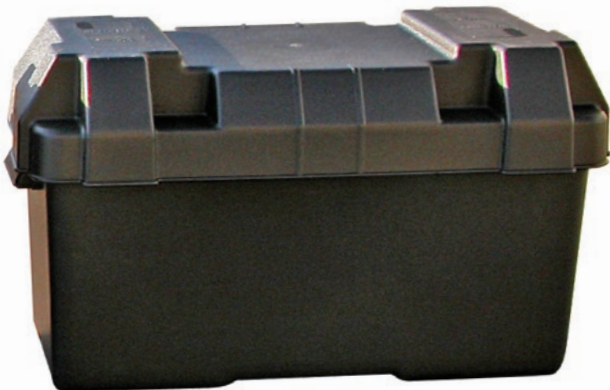

MA98117 BATTERY BOX LARGE

- Internal dimensions: 390 x 180 x 195 (LxWxH mm)
- Tough polypropylene plastic battery box impervious to battery acid
- Complete with tie down strap and mounting hardware



MA98121 BATTERY POWER BOX

- On/Off switch
- 2 x 50 Amp connectors
- Pos and Neg 10mm high current terminals
- Digital voltmeter
- Cig socket output (Back-lit blue LED)
- 2 x 5V, 2.4A USB ports (Back-lit blue LED)
- Internal dimensions 335 x 195 x 205 (LxWxH mm)
- External dimensions 425 x 255 x 325 (LxWxH mm)
- Hold down strap and fittings included
- Resettable circuit breaker



12V Socket Outlet



Voltage Display

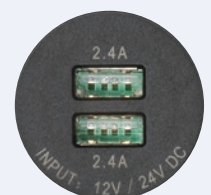

2 x 5V, 2.4A USB Output

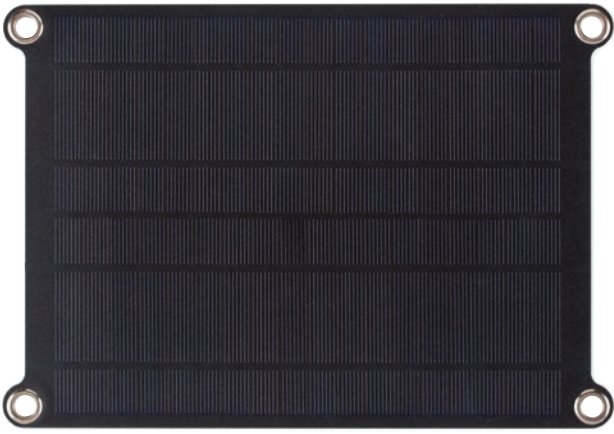

MA1106 OBD SOLAR MAINTENANCE CHARGER

- Maintain 12V batteries
- Charge 5V USB devices
- Connects to car via included OBD plug or alligator clips
- Includes suction hangers x 4

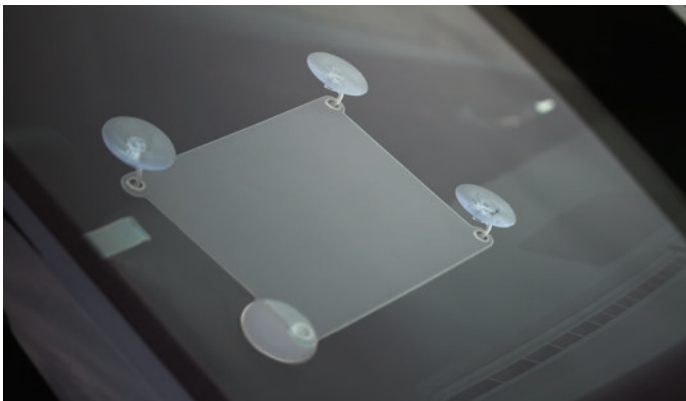

This safe, voltage regulated panel allows connection to the vehicle via the OBD port inside the car OR directly to the battery, for a maintenance solution that stays in the car without running cables from the dash out under the bonnet. It can also charge 5V USB devices like phones and tablets.

ELECTRICAL SPECIFICATIONS

Max Power	5.7W
Voc	21.6V
Output Voltage	5VDC
	14.4VDC
Output Ports	USB2.0
	DC5521
Dimensions	171mm x 246mm
Weight	200g
Operating Temp	-20°C to 70°C



Output Ports



Mounting Points



OBD Charging
Lead Pins



OBD
Charging Lead



Battery Clip Leads



Suction Cups

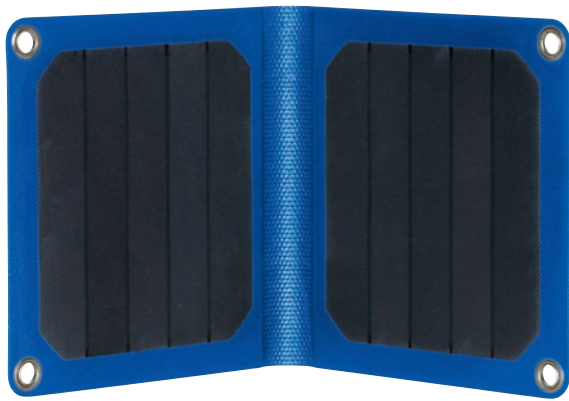

MA1105 PORTABLE USB SOLAR CHARGER

- 5V USB solar charger
- Ultra-light
- Compact
- Water resistant
- Charges portable devices



5V, 1 Amp
USB 2.0 Outlet

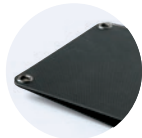

Ultra-Light
Weight 190g

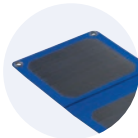

Compact Panels
2mm Thick

ELECTRICAL SPECIFICATIONS		PHYSICAL SPECIFICATIONS	
Power Output (Pmax)	5.3W	Cell Dimensions (mm)	125 x 125 x 2
Stable Voltage Output (V)DC	5	Cell Type	Monocrystalline
Max Power Current (Imp)	0.96A	Weight (g)	190
Rated Voltage (V)DC	5.5	Unfolded Dimensions (mm)	299 x 152 x 3
Power Tolerance (W)	+/-5%	Folded Dimensions (mm)	140 x 152 x 12
Operating Temp	-20°C - +70°C	Output Connectors	USB 2.0

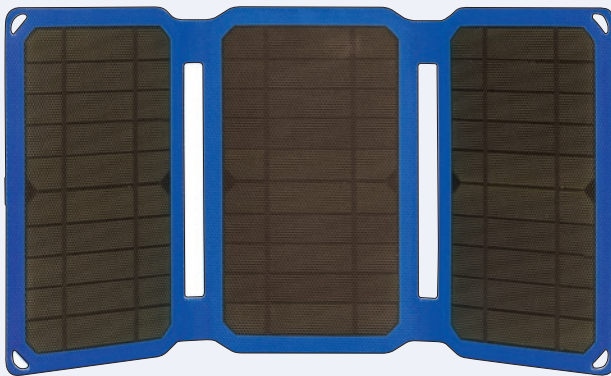

MA1104 PORTABLE USB SOLAR CHARGER

- 5V USB solar charger
- Ultra-light
- Compact
- Water resistant
- Charges portable devices



5V, 3Amp
USB 2.0 Outlet



Ultra-Light
Weight 420g



Compact Panels
2mm Thick

ELECTRICAL SPECIFICATIONS		PHYSICAL SPECIFICATIONS	
Power Output (Pmax)	15W	Cell Dimensions (mm)	225 x 128 x 2
Stable Voltage Output (V)DC	5	Cell Type	Monocrystalline
Max Power Current (Imp)	3A	Weight (g)	420
Rated Voltage (V)DC	6V	Unfolded Dimensions (mm)	497 x 250 x 2
Power Tolerance (W)	+/-5%	Folded Dimensions (mm)	160 x 250 x 18
Operating Temp	-20°C - +70°C	Output Connectors	USB 2.0



MA1103 12V/5V PORTABLE SOLAR CHARGER

- 12V/1A solar maintainer
- 5V/2A USB solar charger
- Ultra-light
- Compact
- Water resistant



Dual Outlets
12V/1A and 5V/2A



Includes USB and
12V Charging Cables



Ultra-Light Weight 500g.
Compact Panels 2mm Thick
Water Resistant

ELECTRICAL SPECIFICATIONS		PHYSICAL SPECIFICATIONS	
Power Output (Pmax)	14W	Cell Dimensions (mm)	225 x 128 x 2
Stable Voltage Output (V)DC	5/14.8	Cell Type	Monocrystalline
Max Power Current (Imp)	2A/0.9A	Weight (g)	500
Rated Voltage (V)DC	6V	Unfolded Dimensions (mm)	495 x 235 x 2
Power Tolerance (W)	+/-5%	Folded Dimensions (mm)	160 x 235 x 25
Operating Temp	-20°C - +70°C	Output Connectors	USB 2.0



The Matson Vehicle System Monitor is a simple device that allows you to tap into the wealth of information from your vehicle computer via your smart device.

After installation and pairing, your smart device gives you a second digital dashboard to display things like speed, RPM, battery voltage, engine temp, average speed, distance and fuel consumption.

The diagnostic function scans and reports fault codes for peace of mind, and the maintenance tracker lets you schedule odometer-triggered reminders for specific service elements.

Finally, the statistics mode lets you monitor your activity for the month, or by day, showing distance travelled, maps of travel routes, max speed, average speed, fuel consumption and even fuel costs, amongst others.

MA98414 BLUETOOTH® VEHICLE SYSTEM MONITORING

- Plugs into OBDII port
- Monitor vehicle conditions in real-time
- Monitor fuel consumption
- Diagnostic function to scan, read and clear fault codes
- Track monthly and daily statistics
- View maps of travel routes and time
- Set reminders for scheduled servicing
- Customise feedback to your vehicle specifics



SPECIFICATIONS	
Bluetooth®	OBD
Operating Temperature	-40°C to 90°C
Input Voltage	12V
Current Draw	1mA
Dimensions	49 x 26 x 23mm
App Name	OBD Plus
Supported	OBDII/EOBD Vehicles
Compatible Protocols	CAN, VPW, PWM, KWP2000, ISO9141
Supported Devices	Android 4.3 and later/iPhone 4S and later/iPad3 and later

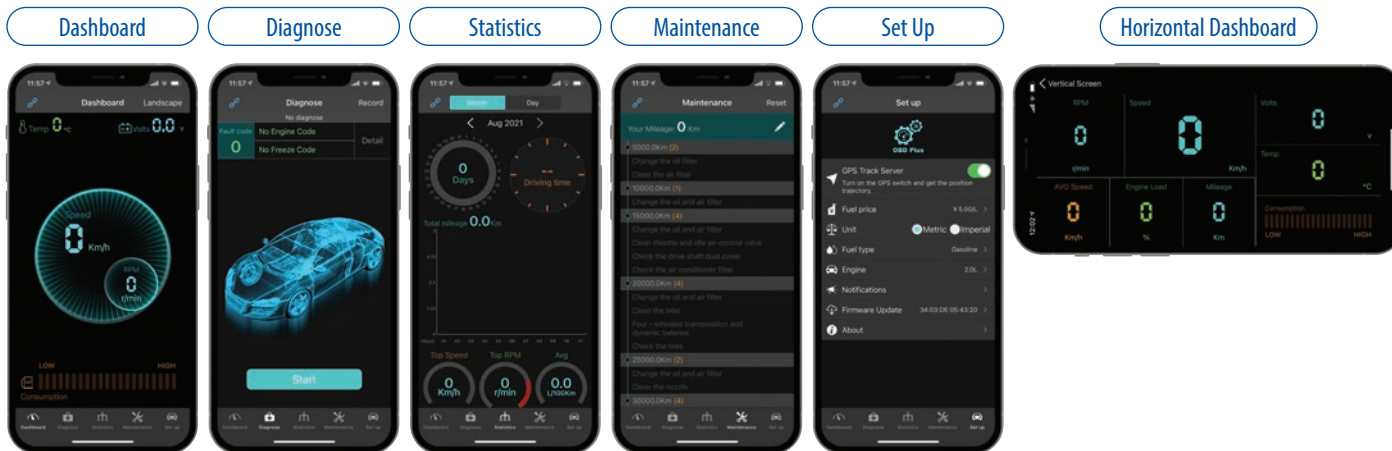

MAMERCHA12 BLUETOOTH® VEHICLE SYSTEM MONITORING MERCHANDISER

- Contains 10 x MA98414
- Dimensions: 200 x 255 x 385 (LxWxH mm)





Monitor multiple batteries, as well as the cranking system and charging system of a vehicle.

The MA98415 can be used to monitor up to four stand-alone 12V batteries, or the combined pack voltage, up to a 48V system. After being connected to the battery, connect the monitor to a mobile device (phone or tablet) via a mobile App.

The App will then alert the user to the voltage of the batteries and fault conditions when the mobile device is within Bluetooth 4.0 range (about 10 metres). It will also record the duration of any engine run time to be able to monitor trip duration.

MA98415 BLUETOOTH® WIRELESS TECHNOLOGY BATTERY MONITOR

- Real-time battery monitoring of up to four devices
- Monitors can be combined for 24V, 36V and 48V systems
- Stores and displays historical data
- Tests vehicle cranking and charging
- Alerts sent to mobile device
- Auto synchronisation (10 metre range)
- Free app for iOS and Android
- Easy DIY installation



SPECIFICATIONS	
Average Current	1.5mA
Input Voltage	6 - 20V
Operating Temperature	-40°C to 40°C
Product Dimensions	5.5 x 3.7 x 1.6cm
Voltage Accuracy	+/-0.03V
Short-circuit Protection	Yes
Reverse Polarity Protection	Yes
Bluetooth® Version	4.0
Bluetooth® Name	Matson Monitor
App Name	Matson Monitor

Home Screen

Cranking Test

Trip Record

Charging Test

Trip Report

24Hr Voltage Graph

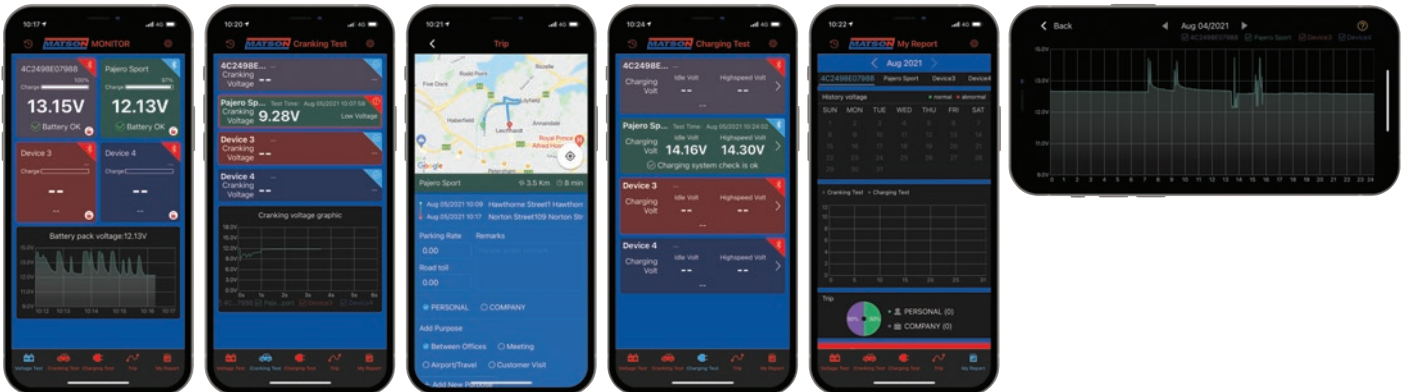

MAMERCHA15 BLUETOOTH® BATTERY SYSTEM MONITORING MERCHANDISER

- Contains 10 x MA98415
- Dimensions: 200 x 255 x 385 (LxWxH mm)





MA98416
12V BATTERY MONITOR

- DIY install in 2 minutes
- Bright colour coded LED's indicate battery voltage
- Easily visible from metres away
- Fast, accurate and reliable
- Water and dust proof to IP67



SPECIFICATIONS	
Applications	All 12V battery sizes and chemistries
Voltage Range	6V - 25V
Power Consumption	2.3mA
Operating Temp	-40°C to +80°C



The MA98416 Battery Monitor is a simple and easy to install device that gives continuous and easy to read information on the charge level of your 12V battery.



12V BATTERY MONITOR MERCHANDISER

- Packs of 10 come in shelf ready merchandiser
- Contains 10 x MA98416



SCAN ME FOR A PRODUCT DEMO



MALED01
VOLTMETER DISPLAY

- Low wattage and power saving
- Displays the voltage of your batteries
- 95cm cable length with cigarette plug
- Display flashes low voltage warning below 11.5V





All Matson battery testers are powered by DHC and feature patented, Single Load Dynamic Resistance (SLDR) technology. SLDR tech places a micro-switched load up to 100 Amps on the battery, simulating real world conditions for consistent and reliable accuracy, and avoids errors due to surface charge, contact impedance and parasitic drain.

SPECIFICATIONS

Application	6V/12V Battery 12V/24V Starting/Charging
Test Range	25 - 3000 CCA (SAE)
Voltage Range	1.5V DC - 30C DC via battery clamp 1.5V DC - 60V DC via test probe
Cable Length	1.8m
Thermal Printer	Integrated
Display	4 lines back-lit LCD
Battery Types	AGM flat plate, EFB (Enhanced Flooded Battery), Flooded, AGM Spiral, VRLA & GEL
Dimensions	27 x 135 x 80mm
Temperature Compensation	Yes
Bluetooth® Connectivity	Yes
App Name	DHC SYNC

BT2100

DIGITAL BATTERY AND SYSTEM TESTER WITH PRINTER AND BLUETOOTH® FUNCTIONALITY

- 6V/12V starting battery tester
- 12V/24V starting/charging system tester
- Tests all 6V & 12V lead-acid starting batteries
- Tests alternator output and charging system output
- Tests Internal Resistance (in Ohms)
- Vehicle rego and VIN input for records/reporting
- Temperature compensation via inbuilt Infra-Red thermometer
- PC connectivity (download results for records/reporting)
- Bluetooth Connectivity (input data via phone)
- Digital reporting, send results by email, text message or social media
- Stores last 2000 tests
- Heavy duty storage case included
- Replacement leads – Part No: BT2100L
- Replacement paper rolls – Part No: BTP2 , for information please go to page 43



POWERED BY **DHC**



Optional Accessories

Inductive Amp Clamp
Part No. BTAMPCLAMP

Voltage Probe
Part No. BTPROBE



SAMPLE PRINT OUT

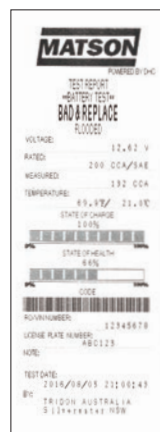

SAMPLE PRINT OUT



Case



BT900 DIGITAL BATTERY AND SYSTEM TESTER WITH PRINTER

- Tests conventional and Stop-Start batteries
- Tests vehicle alternator, starting and charging systems
- Complete test report print-out
- Suits battery types include - regular flooded, AGM flat plate, AGM spiral, GEL, Enhance Flooded (EFB) and AGM (Stop-Start)
- Tests to global standards - SAE (CCA), JIS, EN, DIN & IEC
- Complete over-voltage and reverse polarity protection
- Comes in hard storage case
- Replacement paper rolls – Part No: BTP2, for information please go to page 43



The BT900 uses patented Single Load Dynamic Resistance technology to replicate in-vehicle conditions. By running a micro-switch regulated 100 Amp load through the battery, the BT900 is able to correctly diagnose battery condition without interference from surface charge, high voltage, parasitic draw or contact impedance, increasing accuracy and efficiency.

SPECIFICATIONS

Application	12V Batteries 12V/24V Starting/Charging Systems
Test Range	40 - 2000 CCA (SAE)
Voltage Range	8.0 - 31.5V DC
Cable Length	75cm
Thermal Printer	Integrated
Display	4 line back-lit LCD with adjustable brightness



BT400 BATTERY AND ALTERNATOR TESTER

- Microprocessor controlled
- Easy to read LCD screen
- Reverse polarity protection
- Accurate results in two seconds
- Convenient in-vehicle option tests battery and starting/alternator system in sequence
- No internal battery required



Easy to use 12V battery and 12V/24V starting/alternator system tester
Compatible with both conventional and Start-Stop battery chemistries

SPECIFICATIONS

Application	12V Batteries 12V/24V Electrical Systems
Operation Range	40 - 2000 CCA (SAE)
Voltmeter	8V - 31.5V DC
Suits Chemistries	VRLA/GEL, Flooded, AGM, Flat Plate, AGM Spiral Plate, Start-Stop (EFB & AGM)





BTJ41 DIGITAL STORAGE BATTERY TESTER

- Suits 12V lead acid batteries
- Suitable for batteries from 2AH - 200AH
- Easy operation
- Two line, 16 character LCD display
- Tests batteries as low as 1.5 Volts



50888 DIGITAL BATTERY TESTER

- 100 Amp load tester for 12V batteries only
- This tool duplicates starter motor draw for battery and alternator testing purposes
- Digital display of battery and charging system voltage, and test results



500A2 CARBON PILE BATTERY LOAD TESTER

- 500 Amp variable load carbon pile tester
- Colour-coded, temperature compensated Pass/Fail bands on voltmeter
- Separate voltmeter and ammeter provide easy to monitor battery load tests
- Tests batteries up to 1000CCA
- Fully insulated, heavy duty, colour coded battery clamps and wire leads
- Tests 12V batteries, alternators, regulators and starters
- Built in warning beeper





MA35000 12/24V LITHIUM JUMP STARTER

- Automatic voltage sensing
- Peak current 1200A (12V)
- 35000mAh capacity
- Back-up power for portable devices
- Powerful 3W/250 lumen torch function
- Starts up to 15L diesel vehicles*
- Full safety protections
- Replacement 240V charger – Part No: MA35000C



The next step in the evolution of jump starting technology, lithium jump starters represent maximum energy density at the lightest possible weight.

High quality Lithium Cobalt and Lithium Iron Phosphate (LiFePO4) cells provide long shelf and service life, whether jump starting vehicles or re-charging portable devices.

Comprehensive safety features protect the user and vehicles, allowing peace of mind during storage and operation.

With three sizes in the range, there is a model to suit almost all applications.

SPECIFICATIONS

Battery Capacity	35000mAh
Battery Type	Lithium Ion Phosphate (LiFePO4)
Size	292 x 233 x 79mm
Weight	2700g
Input	15V / 1A
Output	5V / 1A USB
	5V / 2A USB
	12V / 10A
Full Charging Time	8 hours
	12V Jump Starting
Start Current	12V 600A: 24V 300A
	24V Jump Starting
Peak Current	12V 1200A: 24V 600A
Operating Temp	-20°C to 60°C
Lifetime	1000 Cycles plus
Light Output	3W - 250 Lumens
Housing Material	ABS Plastic
Housing Rating	V0 (UL94)

SAFE

- Automatic reverse polarity and short circuit protection, reverse charge protection, over temp protection, cell balancing and audible alarms
- Automatic shut-down in fault conditions
- ABS plastic housing rated to UL94 provision V0 (self-extinguishing)
- Forced cooling period, limited to 1 start per minute. Cranking output limited to 5 seconds over max amp output



SMART

- Automatically detects vehicle system voltage (12V/24V) and adjusts output to suit



POWERFUL

- 35000mAh capacity LiFePO4 cells for stability
- Upgraded jump start clamps
- Pure copper starting cable
- Starts up to 15L diesel engines (*dependant on engine and battery condition)



USEFUL

- 35000mAh storage capacity means the unit can fully charge an iPhone up to 14 times
- 2 x 5V USB outlets
- 3W / 250 Lumen torch for light when you need it most
- 12V 10Amp output socket for powering 12V devices (compressors and inverters etc)



Accessories Included

240V Charger
Part No: MA35000C



Car Charging Lead



Mobile Device Charging Lead
(Apple and Micro USB plugs)





MA21000 12V LITHIUM JUMP STARTER

- 12V 550A starting current
- 21000mAh capacity (77.7Wh)
- Back-up power for portable devices
- Powerful torch function
- Starts up to 7.5L diesel engines*
- Full safety protections



SPECIFICATIONS	
Battery Capacity	21000mAh (77.7Wh)
Size (mm)	225 x 91 x 34
Weight (g)	750
Input	Quick Charge USB-C 5V/2A; 9V/2A
Output	5V/1A USB
	5V/2.1A USB
	12V Jump Starting
Full Charging Time	5.5 hours via Quick Charge
Start Current	550A
Peak Current	1300A
Operating Temp	-20°C to 60°C
Lifetime	3 - 5 years (depending on usage)

Accessories Included



Storage Case



Jump Leads



Car Charging Leads



AC Adaptor



- 1 Power Button
- 2 Charge Level Indicators
- 3 Boost Button
- 4 Powerful Torch
- 5 USB-C Fast Charge Input
- 6 Dual USB Outputs



SAFE

- Automatic reverse polarity and short circuit protection, reverse charge protection, over temp protection, cell balancing and audible alarms
- Automatic shut-down in fault conditions
- Forced cooling period, limited to 1 start per minute. Cranking output limited to 5 seconds over max amp output



POWERFUL

- High quality jump starting leads and powerful Lithium Cobalt cells means enough power to start up to 7.5 Litre diesel motors (*dependent on battery and engine conditions)



USEFUL

- 21,000mAh storage capacity means the unit can fully charge an iPhone8 up to 11 times
- The powerful torch function can provide light when you need it most with the option of a steady beam, SOS and strobe modes



MA10000 MINI 12V LITHIUM JUMP STARTER

- 12V 200A starting current
- 10W wireless device charging
- 10000mAh capacity (37Wh)
- Back-up power for portable devices
- Powerful torch function
- Starts up to 3L diesel engines*
- Full safety protections



SPECIFICATIONS	
Battery Capacity	10000mAh (37Wh)
Size (mm)	151 x 81 x 32
Weight (g)	395
Starting Current	200A
Peak Current	500A
Operating Temp	-20°C to 60°C
Lifetime	(3 - 5 years) 1000 Cycles
Input (Quick Charge)	5V/2.4A, 9V/2A
Output	5V/2.1A USB
	5V/2.4A USB
	9V/2A USB
	10W Wireless
Full Charging Time	12V Jump Starting
	2 Hours (Quick Charge)

Accessories Included



Storage Case



Smart Safe Jump Leads



Charging Leads

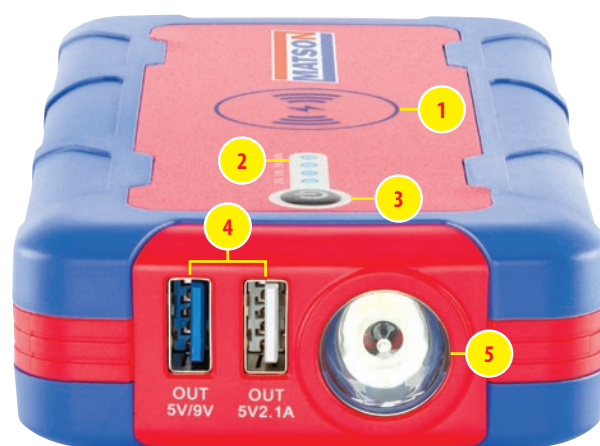

1 Wireless Charging Pad

2 Charge Level Indicators

3 Power Button

4 Dual USB Outputs

5 Powerful Torch



SAFE

- › Automatic reverse polarity and short circuit protection, reverse charge protection, over temp protection, cell balancing and audible alarms
- › Automatic shut-down in fault conditions
- › Forced cooling period, limited to 1 start per minute. Cranking output limited to 5 seconds over max amp output



SMART

- › Combined with the Smart leads, the MA10000 automatically detects if it is correctly connected to a vehicle and warns the user of any errors



POWERFUL

- › High quality jump starting leads and powerful Lithium Cobalt cells means enough power to start up to 3 Litre diesel motors (*dependent on engine and battery conditions)



USEFUL

- › 10,000mAh storage capacity means the unit can fully charge an iPhone6 up to 4 times
- › The powerful torch function can provide light when you need it most, with the option of a steady beam, SOS and strobe modes



Professional quality jump start units designed for workshop conditions. Heavy duty clamps and a robust case combined with high performance long life batteries make these units the tradesman's choice.

SPECIFICATIONS	
Application	12/24V cars, trucks and buses
Battery	2 x 21 Ah AGM batteries
CCA	1000 CCA @ 12V, 500 CCA @ 24V
Peak Amps	3800 A @ 12V, 1900 A @ 24V
Dead Start	Yes
Weight	14.5kg
Cable Length	190cm/1.9m
Cable Size	2 AWG

MA3400 12V/24V HEAVY DUTY PROFESSIONAL JUMP STARTER

- Dead start function
- Built in safety monitoring
- Heavy duty cable and fully insulated clamps
- Ultra high performance sealed AGM battery
- Recharge from 240VAC or 12VDC
- 12V DC power outlet with overload protection and cover
- Charge level indicator
- Heavy duty professional use
- Includes 3 stage, 2 amp charger to ensure optimum battery life
- Replacement batteries available – Part No: MA3400B
- Replacement charger – Part No: MAC02





RA3800 12V/24V HEAVY DUTY JUMP STARTER

- Reverse polarity alarm
- 3 Stage switch-mode 12V 2 Amp charger included
- Drop resistant unbreakable case
- 12V DC power outlet with overload protection
- Analogue voltmeter to display state of charge
- Rechargeable from 240V AC or 12V DC Supply
- ANTIZAP® protection against voltage surges and spikes
- Safety LED (Green Flashing) indicates Anti-Zap surge protection active
- Safety LED (Red) indicates reverse polarity connection
- Reverse polarity audible alarm
- Replacement batteries available – Part No: MA3400B
- Replacement charger – Part No: MAC02



SPECIFICATIONS	
Application	Heavy duty trucks and buses
Battery	2 x 21 Ah AGM batteries
CCA	1000 CCA @ 12V
	500 CCA @ 24V
Peak Amps	3800 A @ 12V
	1900 A @ 24V
Dimensions	36 x 16 x 37cm
Weight	20.4kg
Cable Length	1.5m
Cable Size	35mm ²



MA3400B REPLACEMENT BATTERY

- 500CCA
- 21A/h
- 6.4kg
- 180mm x 167mm x 76mm



MA8000B REPLACEMENT BATTERY

- 1000CCA
- 45A/h
- 14.6kg
- 200mm x 170mm x 165mm



MA8000 12V/24V INDUSTRIAL JUMP STARTER

- 8000 peak Amps starting power
- 1.7m 50mm² high conductivity leads (incl. clamps)
- Industrial grade clamps with brass connection points
- 12V DC power outlet with overload protection
- 12/24V digital voltmeter – indicates the voltage of the battery to be jump started when the clamps are first connected and the selection switch is in the OFF position
- Matson's patented ANTIZAP[®] voltage spike protection – even in the "off" position
- Green flashing light to indicate ANTIZAP[®] protection
- Warning buzzer and LED alert for reverse connection
- On/Off safety switch
- Replacement batteries available – Part No: MA8000B



Affordable and super powerful workshop trolley jump starter.

Producing a massive 8000 Peak Amps and 2000CCA on the 12 volt setting and 4000 Peak Amps and 1000CCA on the 24 volt setting, the MA8000 Thunderbolt is one of the most powerful workshop jump starts available.

Fitted with a stainless steel axle and heavy duty rubber wheels for easy movement around the workshop and yard, this is the go anywhere solution for your heavy duty jump start needs.

SPECIFICATIONS

Application	12/24V cars, trucks and buses
Battery	2 x MA8000B
CCA	2000 CCA @ 12V, 1000 CCA @ 24V
Peak Amps	8000 A @ 12V, 4000 A @ 24V
ANTIZAP [®] Protection	Yes
Weight	40kg
Cable Length	1.7m
Cable Size	50mm ²



INCLUDED Part No: RV210 10 AMP SMART CHARGER FOR RECHARGING

- 12V
- 2A/10A output
- Chemistry selectable





JUMPER LEADS

- Durable high grade insulation material resists acid, oil and chemicals

Part No.	Cable	AMP Capacity	Length	Surge Protection
MA55100AZ	6B&S/15mm ²	400	2.4m	Yes
MA254AZ	3B&S/25mm ²	600	4m	Yes
MA354	2B&S/35mm ²	750	4m	No
MA354AZ	2B&S/35mm ²	750	4m	Yes
MA504AZ	0B&S/50mm ²	900	4m	Yes
MA506AZ	0B&S/50mm ²	900	6m	Yes
MA654AZ	00B&S/65mm ²	1000	4m	Yes
MACUSTOMJUMP	Tridon has the ability to make custom jump leads to suit any application, in almost any configuration			



Matson Antizap® Surge Protection provides total protection against transient voltage surges and spikes when jump starting.

Something as simple as a loose or dirty terminal connection can cause a voltage spike, damaging sensitive and expensive electronics found throughout today's modern vehicles.

Matson Antizap® Surge protection means you have one less thing to worry about when you need to jump start.





Matson Antizap® Surge Protector Service Minders provide total protection against transient voltage spikes or voltage surges generated by modern welding units such as Argon, Arc, MIG, TIG and Plasma Cutters. This prevents the need to disconnect batteries resulting in the loss of stereo and other memories, as well as protecting sensitive electronic components from damage resulting from excessive voltage levels.

Matson Antizap® Surge Protection Service Minders should also be used when carrying out all types of electrical repairs on vehicles. Simply changing a fuse, globe or battery terminal can create voltage spikes resulting in expensive damage to vehicle electronics.



MA20121224 SURGE PROTECTOR SERVICE MINDER 12V/24V

- Ideal for eliminating damage caused by voltage surges and spikes when welding on a vehicle or working on vehicle electrics
- Commercial vehicles, 4WD, automotive and marine applications
- Protects electronics from voltage spikes and surges
- Easy operation with reverse polarity alarm
- Suits 12V / 24V applications



MA224HD SURGE PROTECTOR PERMANENT VEHICLE MOUNT 12V/24V

- Ideal for eliminating voltage surges and spikes created in dual battery systems and winches
- Commercial vehicles, 4WD, automotive and marine applications
- Protects electronics from voltage spikes and surges
- Suits 12V and 24V applications
- Easy installation



MA98304 JUMP CABLE SURGE PROTECTION UPGRADE 12V/24V

- Protects electronics from voltage spikes and surges
- Upgrade existing jump leads
- Suits cables 10 - 14.5mm (outside diameter)
- Suits automotive, 4WD, commercial and marine applications
- Easy installation





MS-1E MEMORY SAVER

- Provides power to 12V vehicle computers while changing vehicle starting battery
- Helps preserve computer memory of radio stations, clocks, user settings etc
- Connects via OBDII port, cig socket or battery clips
- OBDII, cig and battery clip leads included
- Contains 12V 4.5Ah rechargeable SLA battery
- Status warning LED lights
- Replacement charger – Part No: MS-1C
- Replacement OBDII lead – Part No: OBD2



OBD Cable



OBD Plug

12V Cig - Cig
CableClamp - 12V Cig
Cable



MAI301P POWER INVERTER 300 WATT PURE SINE

- Converts 12VDC power from a battery into clean 240VAC power to run 240VAC appliances
- Pure Sine Wave output produces stable power the same as 240VAC mains connection to power sensitive electronic devices without interference to audio, displays or sensitive electronics



REFERENCE GUIDE			
Product	WATT	Product	WATT
Digital Camera	10	Electric Cooler	160
Mobile Charger	10	LED TV	200
Laptop Computer 14"	90	Video Game Console	250
Hand Mixer	100	12" Electric Fan	300

SPECIFICATIONS	
Output Power	300W 1 x USB2.0 (5V 2.1A) & 1 x USB-C (5/9/12V 18W)
Surge Power	600W
Idle Power	≤0.8A
DC Input Voltage	11VDC to 15VDC
Output Voltage	215 - 240VAC (@ rated input voltage)
Output Frequency	50Hz +/-1Hz
Output Waveform	Pure Sine Wave
Efficiency	≤85%
Protection	Overload, Over/Under input voltage, Over temp, short circuit
Operating Temp	-10°C ~ 35°C
Cooling	Thermo-fans
Weight (kg)	1.6
Remote Control	N/A
Dimensions (mm)	254 x 170.5 x 74.2

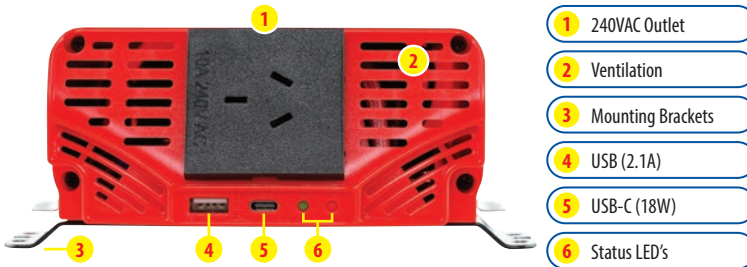

Note: Appliance specifications vary from brand to brand. Please see product label or consult manufacturer to determine specific usage for your application.



MAI601P POWER INVERTER 600 WATT PURE SINE

- Converts 12VDC power from a battery into clean 240VAC power to run 240VAC appliances
- Pure Sine Wave output produces stable power the same as 240VAC mains connection to power sensitive electronic devices without interference to audio, displays or sensitive electronics



REFERENCE GUIDE			
Product	WATT	Product	WATT
Digital Camera	10	LED TV	200
Mobile Charger	10	Video Game Console	250
Laptop Computer 14"	90	12" Electric Fan	300
Hand Mixer	100	Electric Blender	450
Electric Cooler	160	Electric Drill	500

SPECIFICATIONS	
Output Power	600W 1 x USB2.0 (5V 2.1A) & 1 x USB-C (5/9/12V 18W)
Surge Power	1200W
Idle Power	≤0.9A
DC Input Voltage	10.5VDC to 15.5VDC
Output Voltage	215 - 240VAC (@ rated input voltage)
Output Frequency	50Hz +/-0.05Hz
Output Waveform	Pure Sine Wave
Efficiency	≤85%
Protection	Overload, Over/Under input voltage, Over temp, short circuit
Operating Temp	-10°C ~ 35°C
Cooling	Thermo-fans
Weight (kg)	1.8
Remote Control	N/A
Dimensions (mm)	287 x 170.5 x 74.2

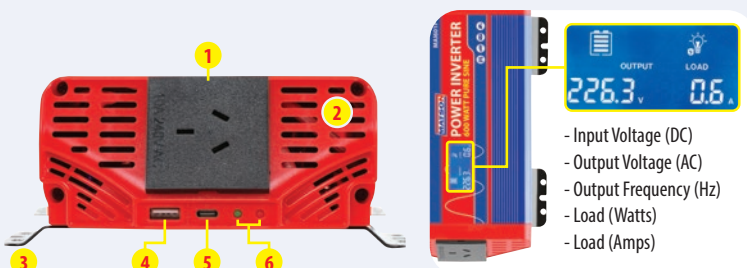

Note: Appliance specifications vary from brand to brand. Please see product label or consult manufacturer to determine specific usage for your application.

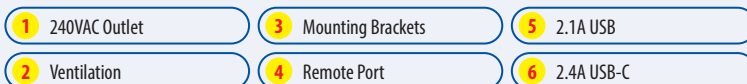



MAI1001P POWER INVERTER 1000 WATT PURE SINE

- Converts 12VDC power from a battery into clean 240VAC power to run 240VAC appliances
- Pure Sine Wave output produces stable power the same as 240VAC mains connection to power sensitive electronic devices without interference to audio, displays or sensitive electronics
- Optional remote control allows discrete installation and control from a distance



MAI399R - Remote on/off switch for pure sine inverter range. Allows discreet installation of inverter while controlling from remote location. Includes cable

REFERENCE GUIDE

Product	WATT	Product	WATT	Product	WATT
Digital Camera	10	LED TV	200	Refrigerator	650
Mobile Charger	10	Video Game Console	250	Food Processor	900
Laptop Computer 14"	90	12" Electric Fan	300	Small Microwave	1000
Hand Mixer	100	Electric Blender	450		
Electric Cooler	160	Electric Drill	500		

SPECIFICATIONS

Output Power	1000W 1 x USB2.0 (5V 2.1A) & 1 x USB-C (5/9/12V 18W)
Surge Power	2000W
Idle Power	≤0.9A
DC Input Voltage	10.5VDC to 15.5VDC
Output Voltage	215 - 240VAC (@ rated input voltage)
Output Frequency	50Hz +/-0.05%
Output Waveform	Pure Sine Wave
Efficiency	≤85%
Protection	Overload, Over/Under input voltage, Over temp, short circuit
Operating Temp	-10°C ~ 35°C
Cooling	Thermo-fans
Weight (kg)	3.5
Remote Control	Optional – Part No: MAI399R
Dimensions (mm)	385 x 210 x 102

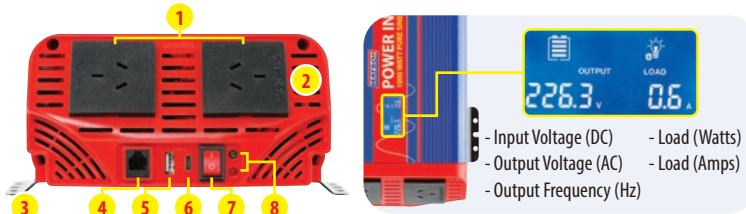

- 1 240VAC Outlet
- 3 Mounting Brackets
- 5 2.1A USB
- 7 On/Off Switch
- 2 Ventilation
- 4 Remote Port
- 6 2.4A USB-C
- 8 Status LED's

Note: Appliance specifications vary from brand to brand. Please see product label or consult manufacturer to determine specific usage for your application.



MAI1501P POWER INVERTER 1500 WATT PURE SINE

- Converts 12VDC power from a battery into clean 240VAC power to run 240VAC appliances
- Pure Sine Wave output produces stable power the same as 240VAC mains connection to power sensitive electronic devices without interference to audio, displays or sensitive electronics
- Optional remote control allows discrete installation and control from a distance



MAI399R - Remote on/off switch for pure sine inverter range. Allows discreet installation of inverter while controlling from remote location. Includes cable

REFERENCE GUIDE

Product	WATT	Product	WATT	Product	WATT
Digital Camera	10	Video Game Console	250	Small Microwave	1000
Mobile Charger	10	12" Electric Fan	300	Microwave	1300
Laptop Computer 14"	90	Electric Blender	450	Window Air Conditioner	1350
Hand Mixer	100	Electric Drill	500	Toaster	1400
Electric Cooler	160	Refrigerator	650	Vacuum Cleaner	1500
LED TV	200	Food Processor	900		

SPECIFICATIONS

Output Power	1500W 1 x USB2.0 (5V 2.1A) & 1 x USB-C (5/9/12V 18W)
Surge Power	3000W
Idle Power	≤1A
DC Input Voltage	10.5VDC to 15.5VDC
Output Voltage	215 - 240VAC (@ rated input voltage)
Output Frequency	50Hz +/-0.05%
Output Waveform	Pure Sine Wave
Efficiency	≤85%
Protection	Overload, Over/Under input voltage, Over temp, short circuit
Operating Temp	-10°C ~ 35°C
Cooling	Thermo-fans
Weight (kg)	3.6
Remote Control	Optional – Part No: MAI399R
Dimensions (mm)	385 x 210 x 102

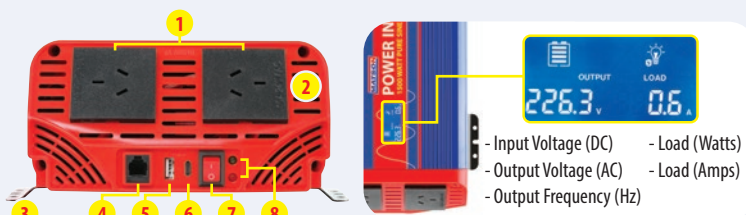

- 1 240VAC Outlet
- 3 Mounting Brackets
- 5 2.1A USB
- 7 On/Off Switch
- 2 Ventilation
- 4 Remote Port
- 6 2.4A USB-C
- 8 Status LED's

Note: Appliance specifications vary from brand to brand. Please see product label or consult manufacturer to determine specific usage for your application.



MAI399R - Remote on/off switch for pure sine inverter range. Allows discreet installation of inverter while controlling from remote location. Includes cable

MAI2001P POWER INVERTER 2000 WATT PURE SINE

- Converts 12VDC power from a battery into clean 240VAC power to run 240VAC appliances
- Pure Sine Wave output produces stable power the same as 240VAC mains connection to power sensitive electronic devices without interference to audio, displays or sensitive electronics
- Optional remote control allows discrete installation and control from a distance



REFERENCE GUIDE					
Product	WATT	Product	WATT	Product	WATT
Digital Camera	10	Video Game Console	250	Small Microwave	1000
Mobile Charger	10	12" Electric Fan	300	Microwave	1300
Laptop Computer 14"	90	Electric Blender	450	Window Air Conditioner	1350
Hand Mixer	100	Electric Drill	500	Toaster	1400
Electric Cooler	160	Refrigerator	650	Electric Heater	2000
LED TV	200	Food Processor	900	Electric Stove	2000

SPECIFICATIONS	
Output Power	2000W - 1 x USB2.0 (5V 2.1A) & 1 x USB-C (5/9/12V 18W)
Surge Power	4000W
Idle Power	≤ 1.6A
DC Input Voltage	11VDC to 15VDC
Output Voltage	210 - 240VAC (@ rated input voltage)
Output Frequency	50Hz +/-1Hz
Output Waveform	Pure Sine Wave
Efficiency	≥ 85%
Protection	Overload, Over/Under input voltage, Over temp, short circuit
Operating Temp	-10°C ~ 35°C
Cooling	Thermo-fans
Weight (kg)	5.3
Remote Control	Optional – Part No: MAI399R
Dimensions (mm)	410 x 250 x 100 (incl mounts)

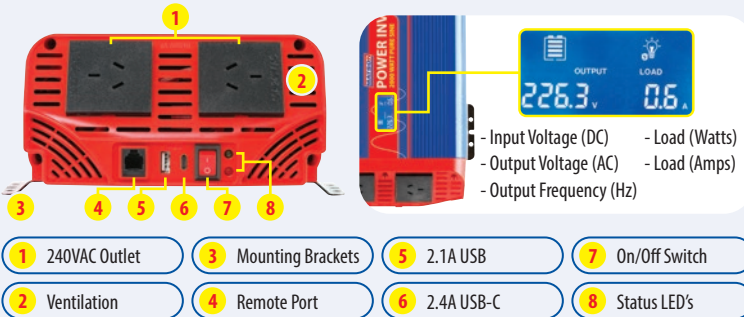

Note: Appliance specifications vary from brand to brand. Please see product label or consult manufacturer to determine specific usage for your application.



MAI399R - Remote on/off switch for pure sine inverter range. Allows discreet installation of inverter while controlling from remote location. Includes cable

MAI3001P POWER INVERTER 3000 WATT PURE SINE

- Converts 12VDC power from a battery into clean 240VAC power to run 240VAC appliances
- Pure Sine Wave output produces stable power the same as 240VAC mains connection to power sensitive electronic devices without interference to audio, displays or sensitive electronics
- Optional remote control allows discrete installation and control from a distance



REFERENCE GUIDE					
Product	WATT	Product	WATT	Product	WATT
Digital Camera	10	Video Game Console	250	Small Microwave	1000
Mobile Charger	10	12" Electric Fan	300	Microwave	1300
Laptop Computer 14"	90	Electric Blender	450	Window Air Conditioner	1350
Hand Mixer	100	Electric Drill	500	Toaster	1400
Electric Cooler	160	Refrigerator	650	Hair Dryer	2200
LED TV	200	Food Processor	900	Evaporative Air Con	2600

SPECIFICATIONS	
Output Power	3000W - 1 x USB2.0 (5V 2.1A) & 1 x USB-C (5/9/12V 18W)
Surge Power	6000W
Idle Power	≤ 2.0A
DC Input Voltage	11VDC to 15VDC
Output Voltage	210 - 240VAC (@ rated input voltage)
Output Frequency	50Hz +/-1Hz
Output Waveform	Pure Sine Wave
Efficiency	≥ 85%
Protection	Overload, Over/Under input voltage, Over temp, short circuit
Operating Temp	-10°C ~ 35°C
Cooling	Thermo-fans
Weight (kg)	6.5
Remote Control	Optional – Part No: MAI399R
Dimensions (mm)	489 x 250 x 100 (incl mounts)

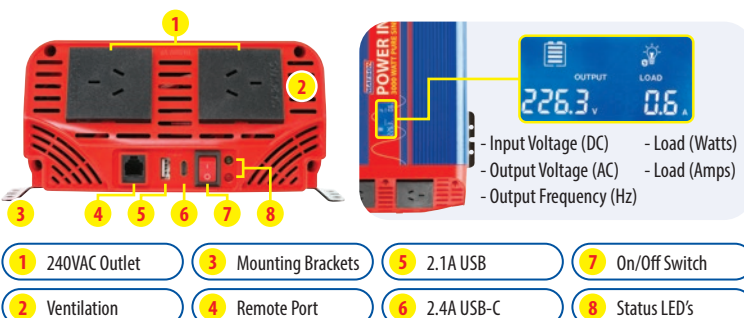

Note: Appliance specifications vary from brand to brand. Please see product label or consult manufacturer to determine specific usage for your application.



BATTERY TO STARTER

Length		00 B&S	2 B&S	2 B&S	3 B&S
		Black	Black	Red	Black
cm	inches	65mm ²	35mm ²	35mm ²	25mm ²
15	6	-	BC6-2B	-	-
20	8	BC8-00	BC8-2B	-	BC8-3
25	10	-	BC10-2B	-	BC10-3
30	12	BC12-00	BC12-2B	BC12-2R	BC12-3
38	15	BC15-00	BC15-2B	BC15-2R	BC15-3
46	18	BC18-00	BC18-2B	BC18-2R	BC18-3
53	21	BC21-00	BC21-2B	BC21-2R	BC21-3
61	24	BC24-00	BC24-2B	BC24-2R	BC24-3
69	27	BC27-00	BC27-2B	BC27-2R	-
76	30	BC30-00	BC30-2B	BC30-2R	BC30-3
84	33	-	BC33-2B	-	-
91	36	BC36-00	BC36-2B	BC36-2R	BC36-3
99	39	-	BC39-2B	-	-
106	42	BC42-00	BC42-2B	BC42-2R	BC42-3
122	48	BC48-00	BC48-2B	-	BC48-3
142	56	BC56-00	-	-	-
153	60	BC60-00	BC60-2B	-	-



SWITCH TO STARTER

Length		00 B&S	2 B&S	2 B&S	3 B&S
		Black	Black	Red	Black
cm	inches	65mm ²	35mm ²	35mm ²	25mm ²
20	8	SW8-00	SW8-2B	SW8-2R	SW8-3
23	9	SW9-00	SW9-2B	-	-
25	10	SW10-00	SW10-2B	SW10-2R	SW10-3
30	12	SW12-00	SW12-2B	SW12-2R	SW12-3
38	15	SW15-00	SW15-2B	SW15-2R	SW15-3
46	18	SW18-00	SW18-2B	SW18-2R	SW18-3
53	21	-	SW21-2B	-	SW21-3
61	24	SW24-00	SW24-2B	SW24-2R	SW24-3
69	27	-	SW27-2B	-	-
76	30	-	SW30-2B	SW30-2R	SW30-3
91	36	SW36-00	SW36-2B	SW36-2R	SW36-3
106	42	-	SW42-2B	-	-
122	48	SW48-00	SW48-2B	SW48-2R	-
132	52	-	SW52-2B	-	-
183	72	-	SW72-2B	SW72-2R	-
208	82	-	SW82-2B	-	-
230	90	-	SW90-2B	SW90-2R	-



BATTERY JOINER

Length		00 B&S	2 B&S	3 B&S
		Black	Black	Black
cm	inches	65mm ²	35mm ²	25mm ²
15	6	BJ6-00	BJ6-2B	BJ6-3
20	8	BJ8-00	BJ8-2B	BJ8-3
23	9	BJ9-00	BJ9-2B	-
25	10	BJ10-00	BJ10-2B	BJ10-3
30	12	BJ12-00	BJ12-2B	BJ12-3
38	15	BJ15-00	BJ15-2B	-
46	18	BJ18-00	BJ18-2B	-
61	24	BJ24-00	BJ24-2B	-



BRAIDED COPPER EARTH STRAP

Length		Battery Earth Strap	Engine Ground Strap
cm	inches		
15	6	ES6	EG6
20	8	ES8	EG8
23	9	ES9	-
25	10	ES10	EG10
30	12	ES12	EG12
38	15	ES15	EG15
46	18	ES18	EG18
61	24	ES24	EG24
76	30	ES30	EG30





MAC1001

- 50A connector to 2 x 50A connectors
- Split cable for wider applications
- 40cm length
- 8B&S, 7mm² cable, Max current 12V, 50A

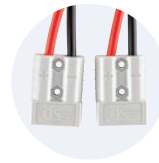

MAC1002

- 50A connector to 2 x 50A connectors
- Stacked connectors for compact applications
- 40cm length
- 8B&S, 7mm² cable, Max current 12V, 50A



MAC1003

- 50A connector to 50A clamps
- 40cm length
- 8B&S, 7mm² cable
- Max current 12V, 50A



MAC1004

- 50A connector to 8mm eyelets
- 40cm length
- 8B&S, 7mm² cable
- Max current 12V, 50A

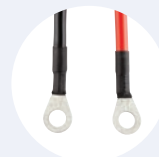

MAC1005

- 50A connector to cig plug
- 40cm length
- Max current 12V, 10A



MAC1006

- 50A connector to cig socket
- 40cm length
- Max current 12V, 10A



MAC1007

- 50A connector to pv plug & socket
- 40cm length
- 8B&S, 7mm² cable
- Max current 12V, 50A



MAC1008

- 50A connector to 8mm eyelets - 50A maxi-fused
- Supplied with single fuse
- 40cm length
- 8B&S, 7mm² cable, Max current 12V, 50A



MAC1009

- 50A connector to waeco plug
- 3 metre length



MAC1010

- 50A connector to engel plug
- 3 metre length



MA1102

Solar Extension Cable 7m

- 50 AMP connectors
- 7mm² twin core cable
- 100% pure copper





MA14

- Solderless, wingnut type
- Allows cable disconnection without tools and without removing terminal from battery
- Stud size 8mm
- Positive and Negative

Post Type	Blister of 1	Blister of 2	Box of 5	Box of 10	Box of 100
Neg	MA14NBL1	-	-	MA14NB10	MA14NB100
Pos	MA14PBL1	-	-	MA14PB10	MA14PB100
Pos/Neg	-	MA14BL2	-	MA14B10	MA14B100



MA142

- Solderless, bolt type
- Allows cable disconnection without removing terminal from battery
- Stud size 8mm
- Positive and Negative

Post Type	Blister of 1	Blister of 2	Box of 5	Box of 10	Box of 100
Neg	MA142NBL1	-	-	MA142NB10	MA142NB100
Pos	MA142PBL1	-	-	MA142PB10	MA142PB100
Pos/Neg	-	MA142BL2	-	MA142B10	-



MA100

- Solderless, bolt type
- OE replacement terminal suits Holden, Toyota, Nissan and more
- Stud size 8mm
- Positive and Negative

Post Type	Blister of 1	Blister of 2	Box of 5	Box of 10	Box of 100
Neg	MA100NBL1	-	-	MA100NB10	MA100NB100
Pos	MA100PBL1	-	-	MA100PB10	MA100PB100
Pos/Neg	-	MA100BL2	-	MA100B10	MA100B100



MA11

- Solderless, saddle type, up to 50mm² (0B&S) cable
- Stripped cable is clamped directly by the saddle
- Accessory cables can connect to saddle bolts
- Universal (fits Pos and Neg)

Post Type	Blister of 1	Blister of 2	Box of 5	Box of 10	Box of 100
Universal	MA11BL1	MA11BL2	-	MA11B10	MA11B100



MA36ST

- Solderless, saddle type, up to 35mm² (0B&S) cable
- Stripped cable is clamped directly by the saddle
- Accessory cables can connect to saddle bolts
- Universal (fits Pos and Neg)

Post Type	Blister of 1	Blister of 2	Box of 5	Box of 10	Box of 100
Neg	MA36STNBL1	-	-	MA36STNB10	MA36STNB100
Pos	MA36STPBL1	-	-	MA36STPB10	MA36STPB100
Pos/Neg	-	MA36STBL2	-	MA36STB10	MA36STB100



MA59

- Solder or crimp type, up to 35mm (2 B&S) cable
- Bell mouth flange for easy cable insertion and housing insulation
- Universal (fits Pos and Neg)

Post Type	Blister of 1	Blister of 2	Box of 5	Box of 10	Box of 100
Universal	MA59BL1	-	-	MA59B10	MA59B100

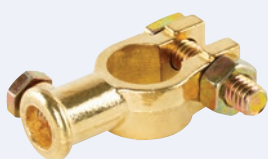

MA32

- Solderless, up to 35mm (2B&S) cable
- End entry emergency applications
- Secure cable via bolt
- Universal (fits Pos and Neg)

Post Type	Blister of 1	Blister of 2	Box of 5	Box of 10	Box of 100
Universal	MA32BL1	MA32BL2	-	MA32B10	MA32B100



MA32ST

- Cable size up to 2 gauge (35mm²)
- Suits small Japanese type battery posts
- End entry emergency applications
- Secure cable via bolt, no crimp or solder required
- Universal size suits Pos and Neg posts

Post Type	Blister of 1	Blister of 2	Box of 5	Box of 10	Box of 100
Universal	-	MA32STBL2	-	MA32STB10	-



MA21

- Solder or crimp type, up to 50mm (0B&S) cable
- Split, side entry type for easy crimp and solder access
- Tin plated
- Negative polarity

Post Type	Blister of 1	Blister of 2	Box of 5	Box of 10	Box of 100
Neg	-	-	-	MA21NB10	MA21NB100
Pos	-	-	-	MA21PB10	MA21PB100



MA23

- Solder or crimp type, up to 50mm (0B&S) cable
- Split, side entry type for easy crimp and solder access
- Tin plated
- Universal polarity (fits Pos and Neg)

Post Type	Blister of 1	Blister of 2	Box of 5	Box of 10	Box of 100
Universal	-	-	-	MA23B10	MA23B100



MA39

- Solderless, up to 50mm (0B&S) cable
- Side entry type secured by twin bolts
- Barrel can be drilled to suit up to 65mm (00 B&S)
- Positive and Negative polarity

Post Type	Blister of 1	Blister of 2	Box of 5	Box of 10	Box of 100
Neg	MA39NBL1	-	-	MA39NB10	MA39NB100
Pos	MA39PBL1	-	-	MA39PB10	MA39PB100
Pos/Neg	-	MA39BL2	-	MA39B10	MA39B100



MA01E

- Solder or crimp type, up to 50mm (0B&S) cable
- Heavy duty end entry barrel type
- Tin plated
- Positive and Negative polarity

Post Type	Blister of 1	Blister of 2	Box of 5	Box of 10	Box of 100
Neg	-	-	MA01ENB5	-	MA01ENB100
Pos	-	-	MA01EPB5	-	MA01EPB100



MA02S

- Solder or crimp type, up to 65mm (00B&S) cable
- Heavy duty side entry barrel type, can join two cables
- Tin plated
- Positive and Negative polarity

Post Type	Blister of 1	Blister of 2	Box of 5	Box of 10	Box of 100
Neg	-	-	MA02SNB5	-	MA02SNB100
Pos	-	-	MA02SPB5	-	MA02SPB100



MA14HD

- Solderless, wingnut type (304 stainless), heavy duty
- Allows cable disconnection without tools and without removing terminal from battery
- Stud size 10mm (304 stainless)
- Positive and Negative

Post Type	Blister of 1	Blister of 2	Box of 5	Box of 10	Box of 100
Neg	MA14HDNBL1	-	MA14HDNB5	-	MA14HDNB100
Pos	MA14HDPBL1	-	MA14HDPB5	-	MA14HDPB100
Pos/Neg	-	MA14HDBL2	-	-	MA14HDB100



MA142HD

- Solderless, bolt type, heavy duty
- Allows cable disconnection without removing terminal from battery
- Stud size 10mm
- Positive and Negative

Post Type	Blister of 1	Blister of 2	Box of 5	Box of 10	Box of 100
Neg	MA142HDNBL1	-	MA142HDNB5	-	MA142HDNB100
Pos	MA142HDPBL1	-	MA142HDPB5	-	MA142HDPB100
Pos/Neg	-	MA142HDBL2	-	-	MA142HDB100



MA143HD

- Solderless, bolt type, heavy duty
- Allows cable disconnection without removing terminal from battery
- Stud size 8mm
- Positive and Negative

Post Type	Blister of 1	Blister of 2	Box of 5	Box of 10	Box of 100
Neg	MA143HDNBL1	-	MA143HDNB5	-	MA143HDNB100
Pos	MA143HDPBL1	-	MA143HDPB5	-	MA143HDPB100
Pos/Neg	-	MA143HDBL2	-	-	MA143HDB100



MA11HD

- Solderless, saddle type, heavy duty, up to 105mm² (000B&S) cable
- Stripped cable is clamped directly by the saddle
- Accessory cables can connect to saddle bolts
- Universal (fits Pos and Neg)

Post Type	Blister of 1	Blister of 2	Box of 5	Box of 10	Box of 100
Universal	MA11HDBL1	MA11HDBL2	MA11HDB5	-	MA11HDB100



MA32HD

- Solderless, heavy duty, up to 65mm (00B&S) cable
- End entry emergency applications
- Secure cable via bolt
- Universal (fits Pos and Neg)

Post Type	Blister of 1	Blister of 2	Box of 5	Box of 10	Box of 100
Universal	MA32HDBL1	MA32HDBL2	MA32HDB5	-	MA32HDB100



MA15PBL1
BATTERY ACCESSORY TERMINAL

- Positive polarity
- Dual 8mm removable stud
- Includes removable brass positive SAE battery post
- Designed to be compatible with squared OE vehicle wiring terminations
- Nickel plated for corrosion and wear resistance
- Terminal cover included

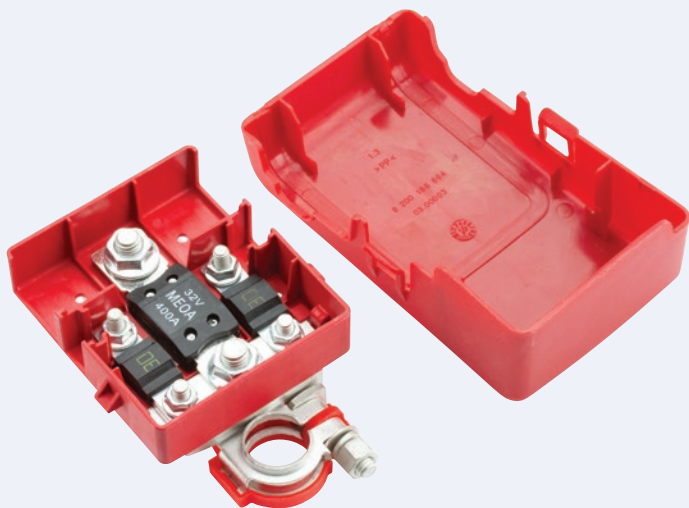
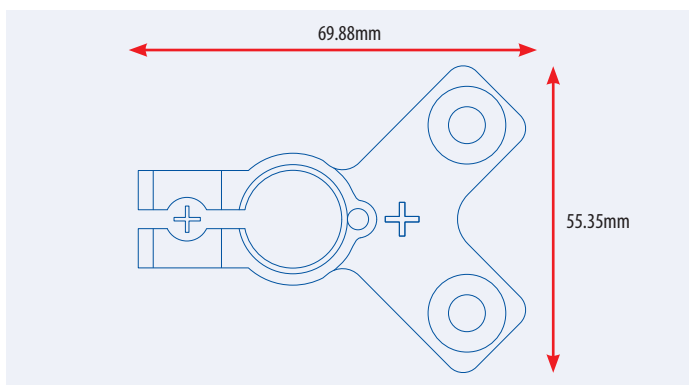

MA17PBL1
FUSED BATTERY ACCESSORY TERMINAL

- Protect accessories from current surges
- Installed correctly, protects against short circuit
- 1 x 400A fused connection point
- 2 x 30A fused connection points
- Positive polarity
- Cover included

Replacement Fuses Available

Part No.	Current Rating	Qty
MA17P-30	30 Amps	1
MA17P-150	150 Amps	1
MA17P-400	400 Amps	1

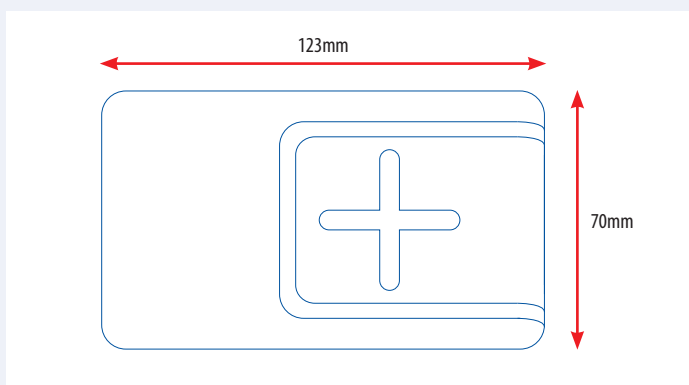

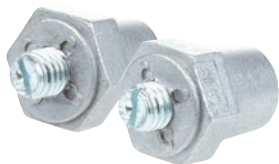

MA1001N & MA1001P

- Alloy construction
- SAE standard terminal size
- Bolt type - 3/8

Polarity	Blister of 2	Box of 10	Box of 50	Box of 100
Neg	-	MA1001P-10	-	MA1001P-100
Pos	-	MA1001N-10	-	MA1001N-100
Pos/Neg	MA1001	-	-	-



MA1002N & MA1002P

- Lead construction
- SAE standard terminal size
- Suits bolt type - 3/8

Polarity	Blister of 2	Box of 10	Box of 50	Box of 100
Neg	-	MA1002P-10	MA1002P-50	MA1002P-100
Pos	-	MA1002N-10	MA1002N-50	MA1002N-100
Pos/Neg	MA1002	-	-	-



MA1003N & MA1003P

- Lead construction
- JIS battery post repair sleeve

Polarity	Blister of 2	Box of 10	Box of 50	Box of 100
Neg	-	MA1003P-10	MA1003P-50	MA1003P-100
Pos	-	MA1003N-10	MA1003N-50	MA1003N-100
Pos/Neg	MA1003	-	-	-



MA1004

- Lead construction
- SAE battery post repair sleeve

Polarity	Blister of 2	Box of 10	Box of 50	Box of 100
Universal	MA1004	MA1004-10	-	MA1004-100



MA1005N & MA1005P

- Side entry terminal covers
- Silicone construction
- Suits MA21, MA23, MA40

Polarity	Blister of 2	Box of 10	Box of 50	Box of 100
Neg	-	-	MA1005P-50	-
Pos	-	-	MA1005N-50	-
Pos/Neg	MA1005-2	-	-	-



MA1006N & MA1006P

- Large end entry terminal covers
- Silicone construction
- Suits MA142HD, MA100, MA14HD, MA14, MA11, MA59, MA32, MA142, MA36ST, MA33, MA01E

Polarity	Blister of 2	Box of 10	Box of 50	Box of 100
Neg	-	-	MA1006P-50	-
Pos	-	-	MA1006N-50	-
Pos/Neg	MA1006-2	-	-	-



MA1007N & MA1007P

- Large side entry terminal covers
- Silicone construction
- Suits MA21, MA23, MA40, MA14, MA14HD, MA142, MA142HD, MA100

Polarity	Blister of 2	Box of 10	Box of 50	Box of 100
Neg	-	-	MA1007P-50	-
Pos	-	-	MA1007N-50	-
Pos/Neg	MA1007-2	-	-	-



MA1008N & MA1008P

- Cable lug covers
- Silicone construction
- Suits cable up to 22mm OD

Polarity	Blister of 2	Box of 10	Box of 50	Box of 100
Pos	-	-	MA1008P-50	-
Neg	-	-	MA1008N-50	-
Pos/Neg	MA1008-2	-	-	-



MA800

- Standard end entry terminal covers
- Silicone construction
- Suits MA14, MA142, MA100, MA11 & MA59 terminals

Polarity	Blister of 2	Box of 10	Box of 50	Box of 100
Pos	-	-	MA800P-50	-
Neg	-	-	MA800B-50	-
Pos/Neg	MA800BL2	-	-	-

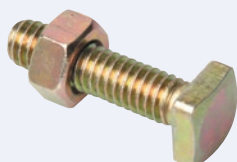

MA6

- Battery terminal bolt
- Bolt type - 1" x 1/4"
- Nut type - 1/4"

Polarity	Blister of 2	Box of 10	Box of 50	Box of 100
Universal	-	MA6B10	MA6B50	-



MABTP50 BATTERY TERMINAL ASSORTMENT PACK

- Selection of popular terminals and covers

Contents

Part No.	Qty	Part No.	Qty
MA11	10	MA32	10
MA14N	5	MA14P	5
MA36STN	5	MA36STP	5
MA100N	5	MA100P	5
Terminal Covers (Red/Black)			6



CABLE JOINING LUGS PLATED COPPER

- Pure copper, tin plated
- Joins two pieces of cable
- Flanged mouth for easy cable insertion
- Crimp, solder or both

Cable Gauge	Cable Conductive Area (mm²)	Length (mm)	Width (OD, mm)	Width (ID, mm)	Box of 10	Box of 100
0	50	38	14	11	MA50CJB10	MA50CJB100
00	65	46	15	12	MA65CJB10	MA65CJB100
000	95	48	17	13	MA95CJB10	MA95CJB100
0000	120	50	18	15	MA120CJB10	MA120CJB100



MA2350L



MA2360L



MA2370L



MA2350Y



MA2350



MA2360



MA2370



MA2350-1



MA2360-1



MA2370-1



MA2350-2



MA2360-2



MA2370-2

ANDERSON STYLE CONNECTORS

- Impact resistant polycarbonate housing and silver plated copper terminals
- Operating temperature -20°C to 105°C

Part No.	Description	AMP Rating	Cable Size	Qty
MA2350Y	Yellow Connector and Lugs	50 Amp	8mm²	1
MA2350	Connector and Lugs	50 Amp	8mm²	2
MA2350-126				126
MA2350-1	Cover	50 Amp	8mm²	1
MA2350-2	Handle	50 Amp	8mm²	1
MA2350LBL2	Lugs	50 Amp	8mm²	2
MA2350LB10				10
MA2350LB100				100
MA2360	Connector and Lugs	175 Amp	35mm²	1
MA2360-44				44
MA2360-1	Cover	175 Amp	35mm²	1
MA2360-2	Handle	175 Amp	35mm²	1
MA2360LBL2	Lugs	175 Amp	35mm²	2
MA2360LB10				10
MA2360LB100				100
MA2370	Connector and Lugs	350 Amp	65mm²	1
MA2370-1	Cover	350 Amp	65mm²	1
MA2370-2	Handle	350 Amp	65mm²	1
MA2370LBL2	Lugs	350 Amp	65mm²	2
MA2370LB10				10
MA2370LB100				100

CRIMP LUGS HEAVY DUTY PLATED COPPER

- 100% pure copper crimp terminals
- Crimp or Solder connections

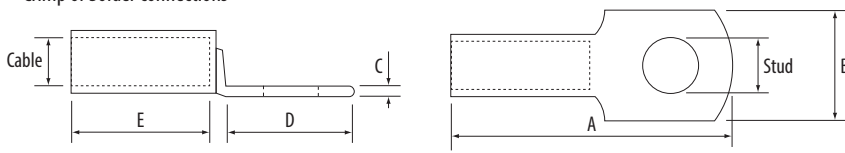

Cable Gauge	Cable Square (mm ²)	Stud Size (Inches)	Stud Size (mm)	Dimensions					Pack of 2	Box of 10	Box of 100
				Length (A)	Width (B)	(C)	(D)	(E)			
16	1.5	3/16	5	18	8	1.0	9	7	-	MA1-5B10	MA1-5B100
16	1.5	1/4	6	20	10	0.8	11	7	-	MA1-6B10	MA1-6B100
13	3	3/16	5	20	10	0.8	11	7	-	MA2-5B10	MA2-5B100
13	3	1/4	6	20	10	0.8	11	7	-	MA2-6B10	MA2-6B100
11	4	1/4	6	22	10	1.0	11	9	-	MA4-6B10	MA4-6B100
11	4	5/16	8	26	12	0.8	15	9	-	MA4-8B10	MA4-8B100
9	6	1/4	6	27	12	1.0	15	9	-	MA6-6B10	MA6-6B100
9	6	5/16	8	27	12	1.0	15	9	-	MA6-8B10	MA6-8B100
7	10	1/4	6	27	12	1.8	14	10	-	MA10-6B10	MA10-6B100
7	10	5/16	8	29	14	1.5	16	10	MA10-8BL2	MA10-8B10	MA10-8B100
7	10	3/8	10	32	16	1.3	19	10	MA10-10BL2	MA10-10B10	MA10-10B100
6	14	1/4	6	37	11	2.3	14	19	-	MA16-6B10	MA16-6B100
6	14	3/16	8	39	14	1.7	16	19	MA16-8BL2	MA16-8B10	MA16-8B100
6	14	3/8	10	41	16	1.5	18	19	MA16-10BL2	MA16-10B10	MA16-10B100
3	27	1/4	6	41	13	2.0	18	20	-	MA25-6B10	MA25-6B100
3	27	3/16	8	41	14	2.4	16	21	MA25-8BL2	MA25-8B10	MA25-8B100
3	27	3/8	10	44	16	2.0	19	21	MA25-10BL2	MA25-10B10	MA25-10B100
2	35	1/4	6	44	15	3.5	17	21	-	MA35-6B10	MA35-6B100
2	35	5/16	8	44	16	3.0	18	21	MA35-8BL2	MA35-8B10	MA35-8B100
2	35	3/8	10	46	18	2.6	20	21	MA35-10BL2	MA35-10B10	MA35-10B100
2	35	1/2	12	50	20	2.3	24	21	MA35-12BL2	MA35-12B10	MA35-12B100
0	54	1/4	6	44	18	3.1	20	17	-	MA50-6B10	MA50-6B100
0	54	3/16	8	47	18	4.0	21	20	MA50-8BL2	MA50-8B10	MA50-8B100
0	54	3/8	10	48	18	3.2	20	22	MA50-10BL2	MA50-10B10	MA50-10B100
0	54	1/2	12	52	21	2.7	24	22	MA50-12BL2	MA50-12B10	MA50-12B100
00	67	3/16	8	54	20	3.5	22	23	MA70-8BL2	MA70-8B10	MA70-8B100
00	67	3/8	10	54	21	3.3	24	24	MA70-10BL2	MA70-10B10	MA70-10B100
00	67	1/2	12	54	21	3.3	24	24	MA70-12BL2	MA70-12B10	MA70-12B100
000	95	3/8	10	60	25	3.9	26	27	MA95-10BL2	MA95-10B10	MA95-10B100
000	95	1/2	12	60	25	3.9	26	27	MA95-12BL2	MA95-12B10	MA95-12B100



MAGPL1 CABLE LUG ASSORTMENT PACK

- 10 pieces of: MA1-5, MA1-6, MA2-5, MA2-6, MA4-8, MA6-6, MA6-8, MA10-6, MA10-10, MA16-6, MA16-8, MA16-10



MAGPL2 CABLE LUG ASSORTMENT PACK

- 10 pieces of: MA25-8, MA25-10, MA35-8, MA35-10, MA35-12, MA50-10, MA50-12
- 5 pieces of: MA70-10, MA70-12, MA95-12

BULK CABLE

- 100% pure copper



Part No.	Cable Gauge	mm ²	Peak Amps Continuous @ 30°c	Colour	Roll Length	Description
MT5C7B-30	5 CORE	-	7	Black	30	Trailer Cable
MT7C7B-30	7 CORE	-	5	Black	30	Trailer Cable
MBS00B-30	00	65	292	Black	30	Battery Cable
MBS00B-100	00	65	292	Black	100	Battery Cable
MBS00R-30	00	65	292	Red	30	Battery Cable
MBS00R-100	00	65	292	Red	100	Battery Cable
MBS0B-30	0	50	246	Black	30	Battery Cable
MBS0B-100	0	50	246	Black	100	Battery Cable
MBS0R-30	0	50	246	Red	30	Battery Cable
MBS0R-100	0	50	246	Red	100	Battery Cable
MBS1B-30	1	40	210	Black	30	Battery Cable
MBS2BL-30	2	35	188	Blue	30	Battery Cable
MBS2B-30	2	35	188	Black	30	Battery Cable
MBS2B-100	2	35	188	Black	100	Battery Cable
MBS2R-30	2	35	188	Red	30	Battery Cable
MBS2R-100	2	35	188	Red	100	Battery Cable
MBS3B-30	3	25	168	Black	30	Battery Cable
MBS3B-100	3	25	168	Black	100	Battery Cable
MBS3R-30	3	25	168	Red	30	Battery Cable
MBS3R-100	3	25	168	Red	100	Battery Cable
MBS4B-30	4	20	135	Black	30	Battery Cable
MBS4B-100	4	20	135	Black	100	Battery Cable
MBS4R-30	4	20	135	Red	30	Battery Cable
MBS4R-100	4	20	135	Red	100	Battery Cable
MBS6B-100	6	14	103	Black	100	Battery Cable
MBS6B-30	6	14	103	Black	30	Battery Cable
MBS6R-100	6	14	103	Red	100	Battery Cable
MBS6R-30	6	14	103	Red	30	Battery Cable
MBS8B-100	8	7	74	Black	100	Battery Cable
MBS8B-30	8	7	74	Black	30	Battery Cable
MBS8R-100	8	7	74	Red	100	Battery Cable
MBS8R-30	8	7	74	Red	30	Battery Cable
C13-30	6	14	-	Copper	30	Braided Earth Strap
MBS2BM-30	2	35	188	Black	30	Tinned Marine 2B&S
MW10	-	10	-	Orange	30	DI Power Flex
MW16-100	-	16	103	Orange	100	DI Power Flex
MW25-100	-	25	168	Orange	100	DI Power Flex
MW50-100	-	50	246	Orange	100	DI Power Flex
TCS4-100	-	1.84	22	Black	100	Twin Sheathed 2 Core Flat
TCS4-30	-	1.84	22	Black	30	Twin Sheathed 2 Core Flat
TCS6B-100	-	4.59	38	Black	100	Twin Sheathed 2 Core Flat
TCS6-30	-	4.59	38	Black	30	Twin Sheathed 2 Core Flat
TCS6BR-100	6	14	82.4	Black/Red	100	Twin Core Sheathed
TCS6BR-50	6	14	82.4	Black/Red	50	Twin Core Sheathed
TCS6BR-30	6	14	82.4	Black/Red	30	Twin Core Sheathed
TCS8BR-100	8	7	59.2	Black/Red	100	Twin Core Sheathed
TCS8BR-50	8	7	59.2	Black/Red	50	Twin Core Sheathed
TCS8BR-30	8	7	59.2	Black/Red	30	Twin Core Sheathed



MA2340
HYDRAULIC CRIMPER

- Comes with eight sets of interchangeable dies to suit lug size 4mm² - 70mm²
- Overall length 320mm
- Up to 45KN crimping force
- Stroke – 10mm
- Hexagonal crimp indentation
- Replacement die set – Part No: MA2340-DS



MA2340-DS
REPLACEMENT DIE SET

- 4, 6, 8, 10, 16, 25, 35, 50, 70mm² sizes



MA2310
COPPER LUG CRIMPER

- Adjustable crimp tool
- Crimps 6mm² - 50mm² lugs
- Crimp jaws rotate for desired gauge
- Overall length 400mm



MA2330
HYDRAULIC CRIMPER

- Comes with ten sets of interchangeable dies to suit lug size 16mm² - 300mm²
- Overall length 500mm
- Up to 100KN crimping force
- Stroke – 22mm
- Hexagonal crimp indentation
- Replacement die set – Part No: MA2330-DS



MA2330-DS
REPLACEMENT DIE SET

- 16, 25, 35, 50, 70, 95, 120, 150, 185, 240 & 300mm² sizes

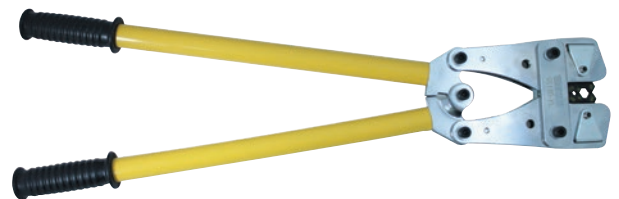

MA2320
COPPER TERMINAL AND LUG CRIMPER

- Heavy duty forged steel crimp tool
- Crimps 6mm² - 120mm²
- 460mm handle for maximum crimp pressure
- Crimp jaws rotate for desired gauge
- Overall length 670mm



MA2341 MECHANICAL INDENT CRIMPER

- Heavy duty forged steel crimp tool
- Crimps 10mm² - 120mm²
- Overall length 570mm



MA2342 MINI CRIMPER

- 1.5, 2, 6, 10 and 16mm² cable sizes
- Length: 280mm
- Ratchet handle system
- Sturdy pressed steel construction
- Ideal for small cable joiner and lug crimping



MA98400 BATTERY MASTER SWITCH

- 250 Amp 12V continuous
- 1000 Amp for 15 seconds
- Rated to a maximum 32V DC
- Dimensions: 67 x 67 x 72mm (LxWxH)

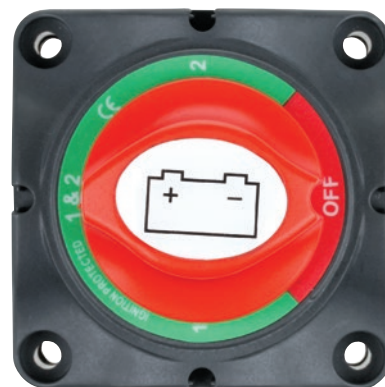

MA98401 4 POSITION MASTER SWITCH

- 250 Amp 12V continuous
- 1000 Amp for 15 seconds
- Rated to a maximum 32V DC
- Select Battery 1, Battery 2, Both or Off
- Dimensions: 67 x 67 x 72mm (LxWxH)



MA2313 PLASTIC BATTERY MASTER SWITCH

- For passenger cars, light trucks, boats and stationary engines
- 1000 Amps max at 12V or 500 Amps at 24V for 5 seconds
- Continuous load maximum 100 Amps



MA2323 BATTERY TERMINAL ISOLATOR

- Simple to install
- No new termination required
- The existing negative terminal fastens to the rear of the master terminal
- Turn the dial to break the connection and disable the battery



**MA98150
HYDROMETER**

- Colour coded float measures specific gravity
- Glass tube does not discolour or tarnish
- Acid resistant rubber bulb and tip



**REPLACEMENT
PAPER ROLLS**



Part No.	Description	Number of Rolls	Roll Width	Roll Dia.	Paper Type	Suits Tester
BTP	Paper Roll	2	38mm	25mm	Thermal	BT301, BT501, BT521
BTPB12	Paper Roll - Box	24	38mm	25mm	Thermal	BT301, BT501, BT521
BTP2	Paper Roll	1	56mm	48mm	Thermal	BT2000, BT2100, BT900
BTP2B10	Paper Roll - Box	10	56mm	48mm	Thermal	BT2000, BT2100, BT900

**MA98110
REPLACEMENT
BATTERY TRAY SMALL**

- Provides safe secure base of battery
- Rust and corrosion resistant
- Plastic coated, heavy gauge steel
- Vented bottom prevents damage from accumulated liquids
- Universal mounting
- Size: 185mm x 280mm



**MA98111
REPLACEMENT
BATTERY TRAY LARGE**

- Provides safe secure base of battery
- Rust and corrosion resistant
- Plastic coated, heavy gauge steel
- Vented bottom prevents damage from accumulated liquids
- Universal mounting
- Size: 185mm x 340mm



**MA98100
BATTERY HOLD DOWN CLAMP SMALL**

- Battery width: 5" (127mm)
- Bolt length: 8.5" (215mm)
- Plastic hold down clamp with metal bolts and brass wing nuts



**MA98101
BATTERY HOLD DOWN CLAMP LARGE**

- Battery width: 7" (175mm)
- Bolt length: 9" (230mm)
- Plastic hold down clamp with metal bolts and brass wing nuts



**MA98105
BATTERY HOLD DOWN CLAMP ADJUSTABLE**

- Battery width: 4 1/2" (115mm) to 7" (175mm)
- Bolt length: 9" (230mm)
- Metal adjustable battery clamp
- Metal bolts with brass wingnuts

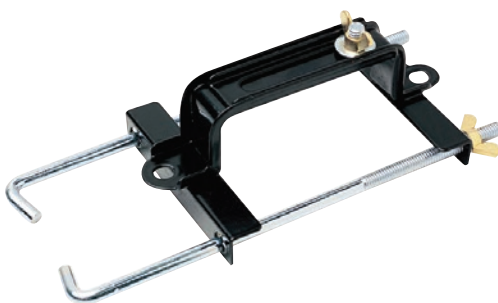

**MA98128
BATTERY HOLD DOWN CLAMP**

- Metal bolts: 8" (205mm)
- Brass wingnuts





MA98103 BATTERY HOLD DOWN BOLTS

- Metal bolts: 10" (230mm)
- Brass wingnuts

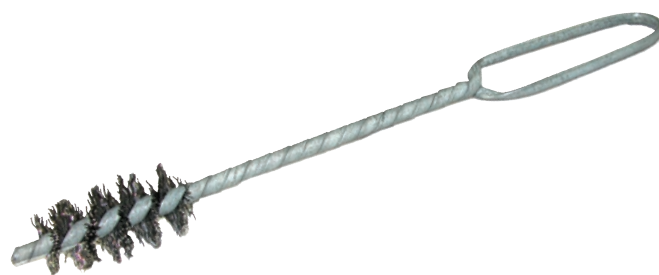

MA5182 BATTERY TERMINAL BRUSH TWISTED WIRE

- Australian made product
- Heavy duty, coarse bristles



MA98125 TERMINAL AND POST CLEANER



MA98122 TERMINAL SPREADER PLIERS

- Forged steel battery terminal spreader plier and reamer
- Reamer cleans inner face of terminal for clean connection
- Plastic coated handle for positive grip



MA98160 BATTERY CLIPS

- Suits Matson battery chargers, testers, memory minders and general 12V accessories
- Rated to 12V, 50 A



MA98260 BATTERY CLIPS

- High quality battery clamps PK 2
- Suits Matson battery chargers, testers, memory minders and general 12V accessories
- Rated to 12V, 75 A



MA17C BOOSTER CLAMP COMMERCIAL

- Fully insulated, thick gauge pressed metal, heavy duty, copper shunt, semi fast-fit lug termination, supplied in pairs
- Rated to 600 Amp



MA98106 BATTERY FILLER WITH SPOUT

- Fully insulated, thick gauge pressed metal, heavy duty, copper shunt, semi fast-fit lug termination, supplied in pairs
- Rated to 600 Amp

Part Number	Page	Part Number	Page	Part Number	Page	Part Number	Page	Part Number	Page
50888	19	BC60-2B	32	ES9	32	MA100PB10	34	MA14HDNB5	35
500A2	19	BC6-2B	32	IR61224	8	MA100PB100	34	MA14HDNBL1	35
AE1000E	5	BC8-00	32	MA01ENB100	35	MA100PBL1	34	MA14HDPB100	35
AE120E	4	BC8-2B	32	MA01ENB5	35	MA10-10B10	39	MA14HDPB5	35
AE150E	4	BC8-3	32	MA01EPB100	35	MA10-10BL2	39	MA14HDPBL1	35
AE300E	4	BJ10-00	32	MA01EPB5	35	MA10-6B10	39	MA14NB10	34
AE500E	5	BJ10-2B	32	MA02SNB100	35	MA10-8B10	39	MA14NB100	34
AE500E-1	4	BJ10-3	32	MA02SNB5	35	MA10-8BL2	39	MA14NBL1	34
AECIG	4	BJ12-00	32	MA02SPB100	35	MA1102	33	MA14PB10	34
BC10-2B	32	BJ12-2B	32	MA02SPB5	35	MA1103	13	MA14PB100	34
BC10-3	32	BJ12-3	32	MA10000	22	MA1104	13	MA14PBL1	34
BC12-00	32	BJ15-00	32	MA1001	37	MA1105	13	MA1-5B10	39
BC12-2B	32	BJ15-2B	32	MA1001N-10	37	MA1106	12	MA15PBL1	36
BC12-2R	32	BJ18-00	32	MA1001N-100	37	MA11B10	34	MA16-10B10	39
BC12-3	32	BJ18-2B	32	MA1001P-10	37	MA11B100	34	MA16-10B100	39
BC15-00	32	BJ24-00	32	MA1001P-100	37	MA11BL1	34	MA16-10BL2	39
BC15-2B	32	BJ24-2B	32	MA1002	37	MA11BL2	34	MA16-6B10	39
BC15-2R	32	BJ6-00	32	MA1002N-10	37	MA11HDB100	35	MA16-6B100	39
BC15-3	32	BJ6-2B	32	MA1002N-100	37	MA11HDB5	35	MA16-8B10	39
BC18-00	32	BJ6-3	32	MA1002N-50	37	MA11HDBL1	35	MA16-8B100	39
BC18-2B	32	BJ8-00	32	MA1002P-10	37	MA11HDBL2	35	MA16-8BL2	39
BC18-2R	32	BJ8-2B	32	MA1002P-100	37	MA120CJB10	38	MA1-6B10	39
BC18-3	32	BJ8-3	32	MA1002P-50	37	MA120CJB100	38	MA17C	44
BC21-00	32	BJ9-00	32	MA1003	37	MA142B10	34	MA17PBL1	36
BC21-2B	32	BJ9-2B	32	MA1003N-10	37	MA142BL2	34	MA20121224	27
BC21-2R	32	BT2100	17	MA1003N-100	37	MA142HDB100	35	MA21000	21
BC21-3	32	BT2100L	17	MA1003N-50	37	MA142HDBL2	35	MA21DCS	9
BC24-00	32	BT400	18	MA1003P-10	37	MA142HDNB100	35	MA21NB10	35
BC24-2B	32	BT900	18	MA1003P-100	37	MA142HDNB5	35	MA21NB100	35
BC24-2R	32	BTAMPCLAMP	17	MA1003P-50	37	MA142HDNBL1	35	MA21PB10	35
BC24-3	32	BTJ41	19	MA1004	37	MA142HDPB100	35	MA21PB100	35
BC27-00	32	BTP	44	MA1004-10	37	MA142HDPB5	35	MA224HD	27
BC27-2B	32	BTP2	44	MA1004-100	37	MA142HDPBL1	35	MA2310	41
BC27-2R	32	BTP2B10	44	MA1005-2	37	MA142NB10	34	MA2313	42
BC30-00	32	BTPB12	44	MA1005N-5	37	MA142NB100	34	MA2320	41
BC30-2B	32	BTPROBE	17	MA1005N-50	37	MA142NBL1	34	MA2323	42
BC30-2R	32	C13-30	40	MA1005P-5	37	MA142PB10	34	MA2330	41
BC30-3	32	EG10	32	MA1005P-50	37	MA142PB100	34	MA2330-DS	41
BC33-2B	32	EG12	32	MA1006-2	37	MA142PBL1	34	MA2340	41
BC36-00	32	EG15	32	MA1006N-50	37	MA143HDB100	35	MA2340-DS	41
BC36-2B	32	EG18	32	MA1006P-50	37	MA143HDBL2	35	MA2341	42
BC36-2R	32	EG24	32	MA1007-2	37	MA143HDNB100	35	MA2342	42
BC36-3	32	EG30	32	MA1007N-50	37	MA143HDNB5	35	MA2350	38
BC39-2B	32	EG6	32	MA1007P-50	37	MA143HDNBL1	35	MA2350-1	38
BC42-00	32	EG8	32	MA1008-2	37	MA143HDPB100	35	MA2350-126	38
BC42-2B	32	ES10	32	MA1008N-50	37	MA143HDPB5	35	MA2350-2	38
BC42-2R	32	ES12	32	MA1008P-50	37	MA143HDPBL1	35	MA2350LB10	38
BC42-3	32	ES15	32	MA100B10	34	MA14B10	34	MA2350LB100	38
BC48-00	32	ES18	32	MA100B100	34	MA14B100	34	MA2350LBL2	38
BC48-2B	32	ES24	32	MA100BL2	34	MA14BL2	34	MA2350Y	38
BC48-3	32	ES30	32	MA100NB10	34	MA14HDB100	35	MA2360	38
BC56-00	32	ES6	32	MA100NB100	34	MA14HDBL2	35	MA2360-1	38
BC60-00	32	ES8	32	MA100NBL1	34	MA14HDNB100	35	MA2360-2	38

Part Number	Page	Part Number	Page	Part Number	Page	Part Number	Page	Part Number	Page
MA2360-44	38	MA365TNB10	34	MA8000B	24	MAI1001P	30	SW10-00	32
MA2360LB10	38	MA365TNB100	34	MA800B-50	37	MAI1501P	30	SW10-2B	32
MA2360LB100	38	MA365TNBL1	34	MA800BL2	37	MAI2001P	31	SW10-3	32
MA2360LBL2	38	MA365TPB10	34	MA800R-50	37	MAI3001P	31	SW12-00	32
MA2370	38	MA365TPB100	34	MA95-10B10	39	MAI301P	29	SW12-2B	32
MA2370-1	38	MA365TPBL1	34	MA95-10B100	39	MAI399R	29	SW12-2R	32
MA2370-2	38	MA39B10	35	MA95-10BL2	39	MAI601P	29	SW12-3	32
MA2370LB10	38	MA39BL2	35	MA95-12B10	39	MALED01	16	SW15-00	32
MA2370LB100	38	MA39NB10	35	MA95-12B100	39	MAMERCHA15	15	SW15-2B	32
MA2370LBL2	38	MA39NB100	35	MA95-12BL2	39	MASS100AZ	26	SW15-3	32
MA23B10	35	MA39NBL1	35	MA95CJB10	38	MBS00B-100	40	SW18-00	32
MA23B100	35	MA39PB10	35	MA95CJB100	38	MBS00B-30	40	SW18-2B	32
MA25-10B10	39	MA39PB100	35	MA98100	44	MBS00R-100	40	SW18-2R	32
MA25-10B100	39	MA39PBL1	35	MA98101	44	MBS00R-30	40	SW18-3	32
MA25-10BL2	39	MA40DCS	9	MA98103	44	MBS0B-100	40	SW21-2B	32
MA254AZ	26	MA4-6B10	39	MA98105	44	MBS0B-30	40	SW21-3	32
MA25-6B10	39	MA4-8B10	39	MA98106	44	MBS0R-100	40	SW24-00	32
MA25-6B100	39	MA4-8B100	39	MA98110	44	MBS0R-30	40	SW24-2B	32
MA25-8B10	39	MA4INONE	7	MA98111	44	MBS1B-30	40	SW24-3	32
MA25-8B100	39	MA50-10B10	39	MA98115	11	MBS2B-100	40	SW27-2B	32
MA25-8BL2	39	MA50-10B100	39	MA98116	11	MBS2B-30	40	SW30-2B	32
MA2-5B10	39	MA50-10BL2	39	MA98117	11	MBS2BL-30	40	SW30-2R	32
MA2-6B10	39	MA50-12B10	39	MA98121	11	MBS2BM-30	40	SW30-3	32
MA32B10	34	MA50-12B100	39	MA98122	44	MBS2R-100	40	SW36-00	32
MA32B100	34	MA50-12BL2	39	MA98125	44	MBS2R-30	40	SW36-2B	32
MA32BL1	34	MA504AZ	26	MA98128	44	MBS3B-100	40	SW36-3	32
MA32BL2	34	MA506AZ	26	MA98150	44	MBS3B-30	40	SW42-2B	32
MA32HDB100	35	MA50-6B10	39	MA98160	44	MBS3R-100	40	SW48-00	32
MA32HDB5	35	MA50-8B10	39	MA98260	44	MBS3R-30	40	SW48-2B	32
MA32HDBL1	35	MA50-8B100	39	MA98260	44	MBS4B-100	40	SW48-2R	32
MA32HDBL2	35	MA50-8BL2	39	MA98304	27	MBS4B-30	40	SW52-2B	32
MA32STB10	34	MA50CJB10	38	MA98400	42	MBS4R-100	40	SW72-2B	32
MA32STBL2	34	MA50CJB100	38	MA98401	42	MBS4R-30	40	SW72-2R	32
MA3400	23	MA5182	44	MA98404	10	MBS6B-100	40	SW8-00	32
MA3400B	24	MA59B10	34	MA98414	14	MBS6B-30	40	SW82-2B	32
MA35000	20	MA59B100	34	MA98415	15	MBS6R-100	40	SW8-2B	32
MA35000C	20	MA59BL1	34	MA98416	16	MBS6R-30	40	SW8-3	32
MA35-10B10	39	MA654AZ	26	MA98504	10	MBS8B-100	40	SW9-00	32
MA35-10B100	39	MA65CJB10	38	MABTP50	38	MBS8B-30	40	SW90-2B	32
MA35-10BL2	39	MA65CJB100	38	MAC02	23	MBS8R-100	40	SW90-2R	32
MA35-12B10	39	MA6-6B10	39	MAC1001	33	MBS8R-30	40	SW9-2B	32
MA35-12B100	39	MA6-8B10	39	MAC1002	33	MS-1C	28	TCS4-100	40
MA35-12BL2	39	MA6B10	37	MAC1003	33	MS-1E	28	TCS4-30	40
MA354	26	MA6B50	37	MAC1004	33	MT5C7B-30	40	TCS6-30	40
MA354AZ	26	MA70-10B10	39	MAC1005	33	MT7C7B-30	40	TCS6B-100	40
MA35-6B10	39	MA70-10B100	39	MAC1006	33	MW16-100	40	TCS6BR-100	40
MA35-6B100	39	MA70-10BL2	39	MAC1007	33	MW25-100	40	TCS6BR-30	40
MA35-8B10	39	MA70-12B10	39	MAC1008	33	MW50-100	40	TCS6BR-50	40
MA35-8B100	39	MA70-12B100	39	MAC1009	33	OBDI	28	TCS8BR-100	40
MA35-8BL2	39	MA70-12BL2	39	MAC1010	33	RA3800	24	TCS8BR-30	40
MA365TB10	34	MA70-8B10	39	MACUSTOMJUMP	26	RV210	25	TCS8BR-50	40
MA365TB100	34	MA70-8BL2	39	MAGPL1	39	SCM54E	6		
MA365TBL2	34	MA8000	25	MAGPL2	39	SCM54E-CS	6		



MATSON

**SETTING THE STANDARD
SINCE 1947**

For further information contact Tridon Customer Service:

AUSTRALIA

Phone: 1300 362 263

Fax: 1300 656 006

**Email: sales@matson.com.au
matson.com.au**

New South Wales

Head Office

21 Derby Street

Silverwater NSW 2128

Victoria

20 Yiannis Court

Springvale VIC 3171

Queensland

90 Old Toombul Road

Northgate QLD 4013

Townsville

1/44-46 Carmel Street

Garbutt QLD 4814

South Australia

8B Myer Court

Beverley SA 5009

Western Australia

1/43 Welshpool Road

Welshpool WA 6106

Tasmania

77 Howick Street

Launceston TAS 7250

Northern Territory

1/53 Hickman Street

Winnellie NT 0820

NEW ZEALAND

Phone: 0508 874 366

Fax: 0800 943 480

**Email: sales@tridon.co.nz
tridon.co.nz**

Auckland

3 Tiri Place

Mt Wellington

Auckland 1060

Christchurch

3/38 Dakota Crescent

Wigram

Christchurch 8042

MALAYSIA

Phone: +603 8066 9770

Fax: +603 8066 9784

Email: sales@toledo.my

No 1, Jalan TPP 5,

Taman Perindustrian Putra

47130 Puchong, Selangor

West Malaysia



CAT093 © Copyright TRIDON AUSTRALIA PTY. LTD. 2022 - MATSON IS A REGISTERED TRIDON BRAND ACN 001 398 698

Reproduction of this catalogue in part or full is not permitted without written approval. Illustrations in this catalogue are for identification purposes only and there may be slight variations between the illustration and actual product. Whilst every effort has been made to ensure that the information contained in this catalogue is accurate at the time of printing, TRIDON AUSTRALIA PTY LTD will not accept responsibility should any inaccuracies be contained herein.