



GROZ

PRODUCT CATALOGUE

◆ MEASURING & MARKING TOOLS ◆ SAWS ◆ PUNCHES ◆ CHISELS ◆ INDUSTRIAL TOOLS ◆ VICES ◆
CLAMPS ◆ PROTRACTORS ◆ PLIERS ◆ CUTTERS ◆ WRENCHES ◆ LUBRICATION EQUIPMENT





Page

2 MEASURING & MARKING TOOLS

6 INDUSTRIAL TOOLS

11 PUNCHES & CHISELS

12 VICES & CLAMPS

13 HACKSAW FRAMES

14 PLIERS AND CUTTERS

15 LUBRICATION EQUIPMENT

16 PAINT MIXERS

17 INDEX



Vee Blocks & Clamps - Toolmakers

- ◆ These V Blocks are very useful for holding work securely during drilling, milling and grinding and also in layout and inspection work.
- ◆ Machine ground to close tolerances.
- ◆ Blocks are made from finely selected tool steel fully hardened between 55 to 60 HRC.
- ◆ Two blocks and two clamps supplied (one pair).
- ◆ Manufactured to BS3731 Grade 2, standard.

Part No.	Length	Width	Height	Width of Vee		Clamping Capacity
				Small	Large	
03000	40mm	32mm	32mm	11mm	20mm	25mm
03001	50mm	37mm	37mm	13mm	28mm	37mm
03002	45mm	40mm	36mm	14mm	28mm	32mm
03003	60mm	40mm	50mm	17mm	25mm	30mm
03004	70mm	45mm	40mm	17mm	33mm	37mm



Vee Block & Clamp Set - Super Precision

- ◆ Non protruding clamp type.
- ◆ Each block incorporates 2 x 90° Vee's of different capacities identical to the Vee's of its matching block.
- ◆ Supplied with 1 x pair of clamps. This type of clamp allows the blocks to be used on their side faces in addition to being used on the base. Blocks are made from finely selected tool steel fully hardened between 55 to 60 HRC.

Part No.	Length	Width	Height	Width of Vee		Clamping Capacity
				Small	Large	
03080	70mm	63mm	45mm	25mm	30mm	37mm

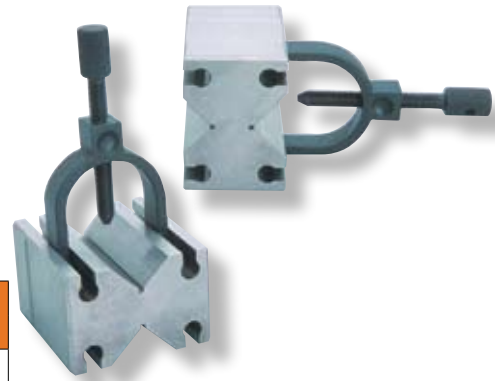

Vee Blocks - Cast Iron

- ◆ Blocks are precisely ground and machined square and parallel.
- ◆ Vee's are 90° centred.
- ◆ Manufactured and supplied in numbered pairs.
- ◆ Handy for holding large jobs where clamping is not necessary.

Part No.	Length	Width of Vee	Height	Width
03100	75mm	45mm	60mm	33mm
03101	100mm	56mm	65mm	40mm
03106	300mm	128mm	200mm	150mm



Adjustable Bevel

- ◆ A useful tool for marking dovetails and other unusual angles.
- ◆ Polished wood stock & brass tips.
- ◆ Blade is blackened - for use on inside or outside corners for perfect layout.
- ◆ Blade adjustment is achieved via a forged steel wing nut.

Part No.	Length
39400	250mm

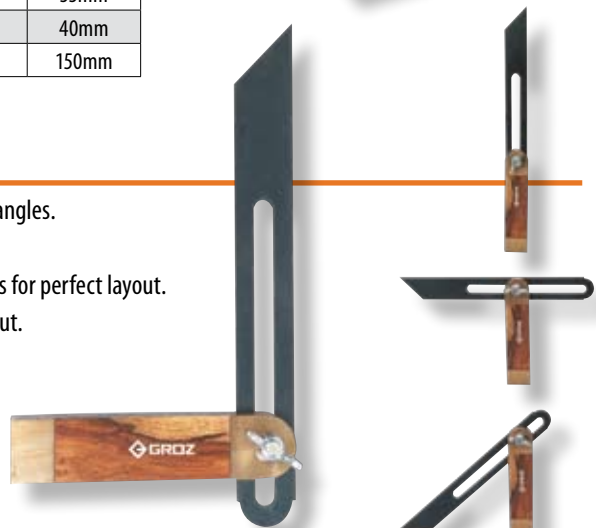

Spring Calipers & Dividers - With Quick Nut

- ◆ Calipers have spring joint for precision settings.
- ◆ The fulcrum stud has a large bearing surface that prevents the side deflection of legs.
- ◆ Divider points are hardened for increased wear resistance.
- ◆ Manufactured from finely polished carbon steel.
- ◆ Quick adjusting nut assists in making quick & positive adjustments.



Quick Nut: Save time in opening and closing when a variety of measurements have to be taken consecutively



Inside Caliper	
Part No.	Size
01431	100mm
01432	150mm
01433	200mm
01434	250mm
01435	300mm

Outside Caliper	
Part No.	Size
01441	100mm
01442	150mm
01443	200mm
01444	250mm
01445	300mm

Spring Dividers	
Part No.	Size
01451	100mm
01452	150mm
01453	200mm
01454	250mm
01455	300mm

Firm Joint Calipers

- ◆ Ruggedly constructed, legs are held by a nut to provide a firm friction joint.
- ◆ Size refers to the length of the legs.
- ◆ Their actual measuring capacity is about 1/3 greater than the given size of the legs.

Inside Caliper	
Part No.	Size
01500	100mm
01502	150mm
01503	200mm
01504	250mm
01505	300mm

Outside Caliper	
Part No.	Size
01520	100mm
01522	150mm
01523	200mm
01524	250mm
01525	300mm



Jenny Calipers

- ◆ Made from carbon steel, the legs are exceptionally rugged and well finished.
- ◆ The leg that holds the adjustable point is offset and the locating lug is incorporated in the straight leg.
- ◆ Useful in layout work for locating and testing centres, laying off distances from an edge etc.

Part No.	Size
01540	150mm



Degree Protractor - Round Head

- ◆ Manufactured from stainless steel.
- ◆ The head has permanently deep edged graduations 0° to 180°.
- ◆ An ideal tool for machinists, draftsmen and mechanics for setting bevels, transferring angles, small square tasks, checking cutter clearance within limits etc.
- ◆ Graduated from 0°-180° in opposite directions.
- ◆ Adjustable arm set with knurled thumbnut.

Part No.	Length
01220	150mm

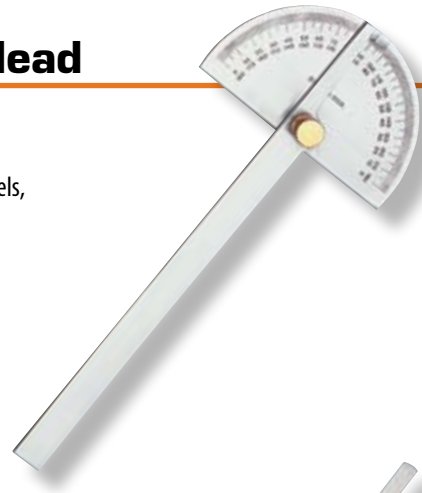

Depth Gauge With Protractor

- ◆ Graduated from 0°-180° in both directions, the blade is adjustable throughout the length.
- ◆ Blade is adjustable angularly to any desired angle for use as a protractor and also lengthwise when used as a depth gauge.
- ◆ Steel rule graduated in both imperial & metric dimensions.

Part No.	Length
01221	150mm

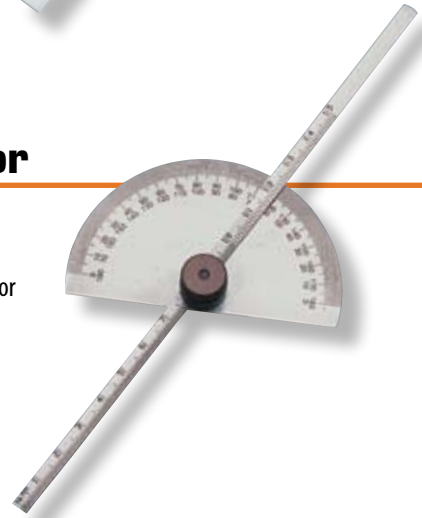

Depth and Angle Gauge

- ◆ For measuring depths & angles.
- ◆ Head graduated on both sides 15°, 30° & 45° and 150mm steel rule can be easily set on any of these angles by knurled nut.

Part No.	Length
01214	150mm
01216	225mm
01217	300mm



Brass Caliper

- ◆ A handy pocket caliper made from solid brass.
- ◆ Close dovetail design ensures smooth motion and provides accurate measurement.
- ◆ Graduation markings are in metric and imperial.
- ◆ Ideal for taking measurements on small objects.

Part No.	Measuring Range
01300	0-75mm

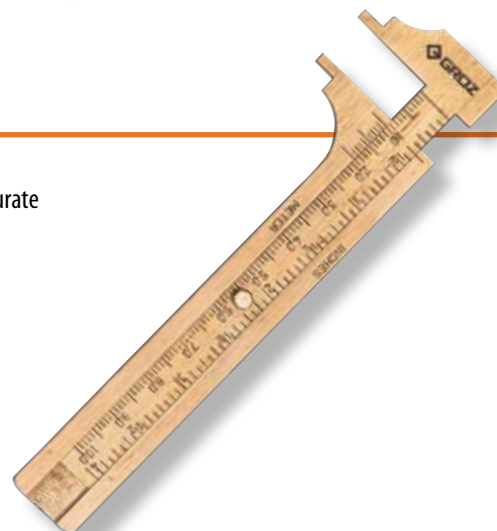

Scriber with Magnet

- ◆ Carbide tip on one end for marking on hard surfaces, permanent magnet on opposite end for picking up small parts.

Part No.	Length
03221	150mm



Engineer's Tool Sets

- ◆ Two sets of quality tools suitable for turning and allied trades and for fitting and general trades.
- ◆ Each set of tools is fitted into specially designed and durable wallets.

6 Piece Set - Contents

Part No.	Description	Size
03600	Inside Calipers	100mm
	Outside Calipers	100mm
	Screw Cutting Gauge	-
	Steel Rule	150mm
	Pocket Scriber	89mm
	Centre Punch	4mm



7 Piece Set - Contents

Part No.	Description	Size
03601	Spring Dividers	100mm
	Jenny Calipers	100mm
	Engineer's Precision Square	100mm
	Double Ended Scriber	190mm
	Steel Rule	150mm
	Centre Punch	4mm
	Adjustable Tap & Reamer Wrench	



Punch Sets

Number Punch Sets 9 Piece

- ◆ Manufactured from high quality steel, punches are induction hardened.
- ◆ The hardness at stamping end is maintained 58-62 HRC and striking end is tempered to 38-43 HRC. This prevents the punch from splintering during use.

NB: No. 6 stamp can be used as No. 9

Part No.	Stamp Size
25902	3mm
25904	5mm
25905	6mm
25906	8mm
25907	10mm
25908	12mm

Letter Punch Sets 27 Piece

- ◆ Manufactured from high quality steel, punches are induction hardened.
- ◆ The hardness at stamping end is maintained 58-62 HRC and striking end is tempered to 38-43 HRC. This prevents the punch from splintering during use.

Part No.	Stamp Size
26102	3mm
26104	5mm
26105	6mm
26106	8mm
26107	10mm
26108	12mm



Drill Sleeves – Hardened & Ground

- ◆ Drill sleeves are used to adapt smaller morse taper shank tools to larger machine spindles.
- ◆ The concentricity and taper angles are precisely controlled which allows perfect locking movement to the tool held.
- ◆ Made from high tensile steel and fully hardened and ground - internally and externally.
- ◆ A Grade - DIN Standard 2185

Part No.	Morse Taper	
	Outside	Inside
08420	MT2	MT1
08421	MT3	MT1
08423	MT3	MT2
08424	MT4	MT2
08426	MT4	MT3
08429	MT5	MT4
08430	MT6	MT4
08431	MT6	MT5



Drill Drift Key

- ◆ Used for quickly removing taper shank drill or reamers from sleeves or sockets.
- ◆ Accurately hardened for increased resistance to wear.
- ◆ DIN Standard 317.

Part No.	Morse Taper
08601	MT1 & MT2
08602	MT3
08603	MT4
08605	MT5 & MT6

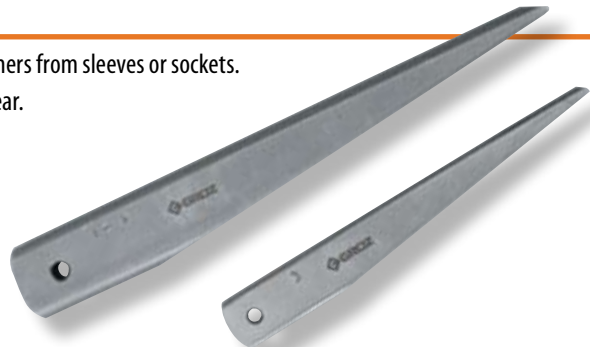

Adjustable Tap & Reamer Wrenches - Bar Type

- ◆ The straight handle design of these tap wrenches provides greater leverage, particularly when working with large diameter taps.
- ◆ Zinc die cast body with hardened steel jaws.

Part No.	Length mm	Jaw Holding Capacity	
		Square	Tap
09200	160mm	2-5mm	M2-M6
09201	180mm	2-6.3mm	M2-M8
09202	275mm	4-9mm	M5-M14
09203	375mm	4.9-12mm	M6-M18



Tap Wrench - T Handle Type

- ◆ The tap wrench is specifically designed to give the user the reach and leverage required for accurate tapping.
- ◆ It holds taps reamers, screw extractors and other hand turned tools.
- ◆ The T-handle or the ratchet permit the handle to be positioned so that leverage can be applied when working in confined spaces.

Type	Part No.	Length	Jaw Holding Capacity	
			Square	Tap
Regular	09302	70mm	3.15-5mm	M4-M6
	09304	90mm	5-8mm	M6-M12
Ratchet	09320	86mm	2.6-5.5mm	M4-M6
	09321	111mm	4.6-8mm	M6-M10

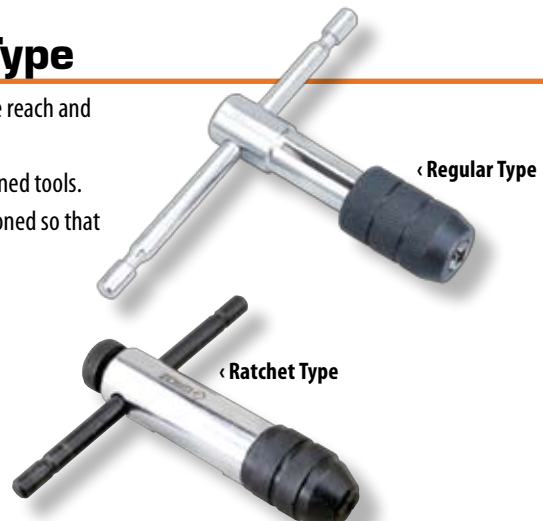

Die Holders (Stocks) For Round Dies

- ◆ The range is best suited for applications requiring efficient and clean cutting of external threads.
- ◆ Die holders have a rugged construction with heavy duty set screws that hold the die firmly in place.
- ◆ Acc DIN 225 - Bodies made from die cast with chrome plated handles.

Part No.	Length	Suitable for Die Size
Acc DIN 225		
09102	224mm	25 x 9mm
Professional Quality		
09110	6 1/2"	13/16"
09111	8 1/4"	1"
09112	10"	1 5/16"
09113	12 3/8"	1 1/2"
09114	15 3/8"	2"

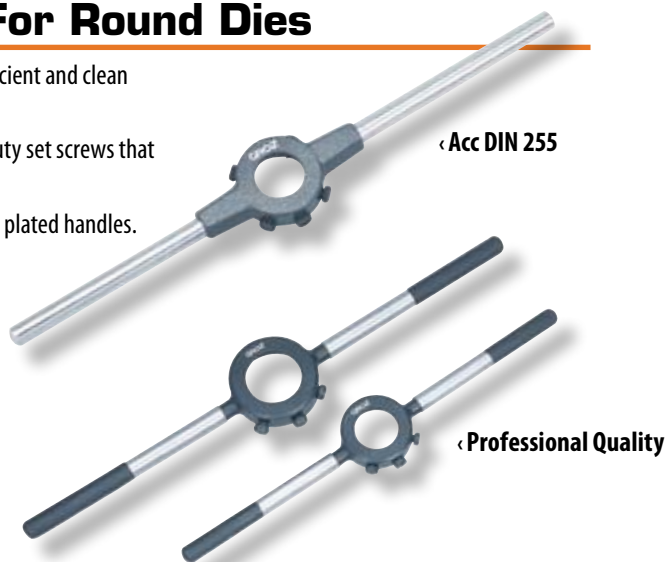

Hand Taps – Carbon Steel

- ◆ Taps are used for cutting internal threads in predetermined holes.
- ◆ These perform best in materials where the cutting action results in chips which break up readily and do not present problems of chip disposal.

Imperial Part No.	Nominal Size (inch)	TPI (thread per inch)	Metric Part No.	Nominal Size (mm)	Pitch (mm)
09402	1/8	40	09606	6	1.00
09404	3/16	24	09608	8	1.25
09406	1/4	20	09610	10	1.50
09408	5/16	18	09612	12	1.75
09409	3/8	16	09614	14	2.00
09411	1/2	12	09616	16	2.00
09413	5/8	11	09618	18	2.50
09415	3/4	10	09620	20	2.50



Taper
for quick easy start, will not cut to bottom of hole

Second
to increase the size of the cut

Bottom
to follow through and cut right to the bottom

◀ Set of three

Deburring Tool Holder Set

- ◆ Tools designed for 90° countersink and deburring operations.
- ◆ Cutters have approved and tested cutting geometry with precisely ground heads that result in clean and chatter free chamfers.
- ◆ The single cutting edge allows fast removal of stock.
- ◆ These can be used in a variety of material in both portable and machine operation.
- ◆ These cutters can be resharpened by the use of a small mounted grinding wheel inserted into the hole or on axial relief sharpening fixtures.

Part No.	Die of Cut		Shank Dia.	
	Min.	Max.		
12101	2mm	5mm	6.35mm	1/4"
	5mm	10mm	6.35mm	1/4"
	10mm	15mm	6.35mm	1/4"
	15mm	20mm	12.70mm	1/2"
	20mm	25mm	12.70mm	1/2"



Wheel Dressers and Cutters

- ◆ Designed for dressing, truing, sharpening & removing glaze from solid abrasive wheels.
- ◆ Handle is ergonomically designed for comfortable grip.
- ◆ Cutters have star shaped teeth.



Part No.	Dresser Wheel Range	Dresser Length	Cutter Diameter	Spare Cutter Part No. (Set of 4)
12070	500mm	255mm	30mm	12080
12071	750mm	270mm	38mm	12081
12072	Large Size	320mm	60mm	12082

Hollow & Arch (Leather) Punches

- ◆ Ideal for use on leather, plastic, fibre etc.
- ◆ The precisely ground cutting edge is induction hardened & tempered for long life. Special design cutting tips prevents jamming of material inside the punch.
- ◆ Sizes 26mm onwards have forged (bell type) construction.

Hollow Punches

Part No.	Hole Diameter
26305	5mm
26306	6mm
26309	9mm
26310	10mm
26311	11mm
26312	12mm
26314	14mm
26316	16mm
26319	19mm
26320	20mm
26325	25mm

Arch Punches

Part No.	Hole Diameter
26327	27mm
26329	29mm
26330	30mm
26332	32mm
26333	33mm
26335	35mm
26338	38mm

Hollow Punch Set 6 piece

Part No.	Hole Diameter
26391	5, 6, 8, 10, 11 & 12 mm



Box Wrenches

- ◆ Manufactured from high quality steel tubing, these double ended box wrenches have a different socket size on each end.
- ◆ Thin and long body allows these to be used to loosen or tighten nuts and bolts in narrow, recessed areas. Supplied with tommy bars.

Metric	Nominal Size	Length	Tommy Bar	
Part No.	mm	mm	Length	Diameter
32000	6 x 7mm	102mm	77mm	3mm
32001	8 x 9mm	102mm	102mm	6mm
32002	10 x 11mm	102mm	102mm	6mm
32003	12 x 13mm	102mm </td <td>102mm</td> <td>6mm</td>	102mm	6mm
32004	14 x 15mm	127mm	152mm	9mm
32005	16 x 17mm	127mm	152mm	9mm
32006	18 x 19mm	127mm	152mm	9mm
32007	20 x 21mm	127mm	152mm	9mm
32008	22 x 23mm	127mm	152mm	9mm
32009	24 x 25mm	152mm	203mm	12mm
32010	26 x 27mm	152mm	203mm	12mm

Imperial	Nominal Size	Length	Tommy Bar	
Part No.	inch	mm	Length	Diameter
32100	1/4" x 5/16"	102mm	102mm	6mm
32101	5/16" x 3/8"	102mm	102mm	6mm
32102	3/8" x 7/16"	102mm	102mm	6mm
32103	1/2" x 9/16"	127mm	152mm	9mm
32104	9/16" x 5/8"	127mm	152mm	9mm
32105	11/16" x 3/4"	127mm	152mm	9mm
32200	13/32" x 3/8"	76.5mm	77mm	5mm
32201	21/64" x 9/32"	76.5mm	77mm	5mm



Box Wrench Sets

Metric Set 6 Piece

Part No.	Set Contains
32019	8 x 9mm, 10 x 11mm, 12 x 13mm, 14 x 15mm, 16 x 17mm, 18 x 19mm plus 2 tommy bars in a plastic pouch

Imperial Set 6 Piece

Part No.	Set Contains
32109	1/4" x 5/16", 5/16" x 3/8", 3/8" x 7/16", 1/2" x 9/16", 9/16" x 5/8", 11/16" x 3/4" plus 2 tommy bars in a plastic pouch



Plier Style Riveter

- ◆ 3 jaw construction offers 30% more grip than regular 2 jaw types.
- ◆ Manufactured from heavy gauge (2.5mm) sheet metal.
- ◆ Riveter jaws made from sintered powder metallurgy, full hardened and non wearing.
- ◆ Supplied complete with 4 hardened & replaceable nose bushes for fastening rivets.
- ◆ Extra long length.
- ◆ Includes spanner for changing nose buses.

Part No.	Length	Capacity (Diameter)
31651	265mm	2.4, 3.2, 4.0, 4.8mm



Lazy Tong Riveter

- ◆ 3 jaw construction offers 30% more grip than regular 2 jaw types.
- ◆ Heavy duty riveter, suited for continuous and repetitive applications.
- ◆ Riveter jaws made from sintered powder metallurgy, full hardened and non wearing.
- ◆ Levers have a riveted construction as opposed to a bolted style, offering more rigidity.
- ◆ Supplied complete with 5 hardened & replaceable nose bushes for fastening rivets.

Part No.	Length (Closed)	Length (Open)	Capacity (Diameter)
31650	300mm	810mm	2.4, 3.2, 4.0, 4.8, 6.4mm

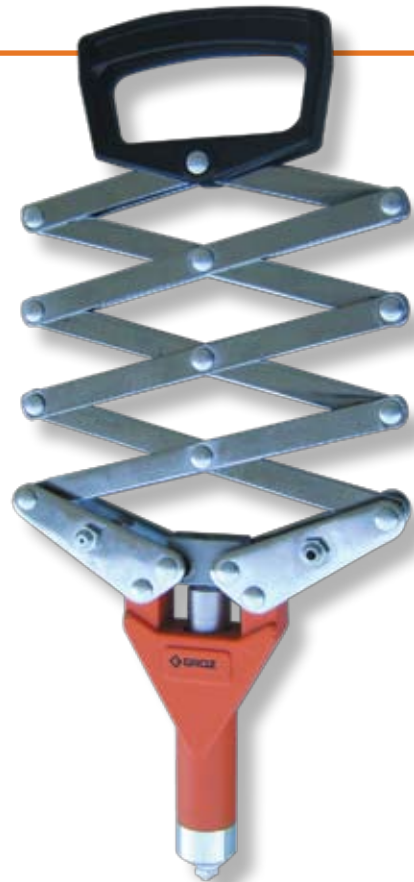

Automatic Centre Punch - Heavy Duty

- ◆ Single hand operated, spring loaded punch.
- ◆ Built in mechanism delivers a punch with the pressing of the head.
- ◆ Depth of impression is variable and can be adjusted from light marking to heavy blows by turning the knurled head.
- ◆ Round shank with a clean and well cut knurling for positive non-slip grip.
- ◆ Tips made from hardened steel which can be removed for re-sharpening or replacement.



Part No.	Dia.	Length
25010	18mm	146mm

Pin Punch Set - 200mm Long

- ◆ Made from tool steel.
- ◆ Knurled body for easy gripping.
- ◆ Black oxidised finish.
- ◆ Front taper and back head in ground finish.
- ◆ Length of pin - 90mm.
- ◆ Set of 5 packed in a pouch.



Part No.	Pin Dia.
25508	3, 5, 6, 8 & 9.5mm

Nail Punches - Square Head

- ◆ Nail punches are designed for driving nail heads below the surface of wood.
- ◆ The working end is cupped to follow the nail head without sliding off.
- ◆ Made from hardened & tempered carbon steel.
- ◆ Knurled body for easy gripping.
- ◆ Black oxidised finish.
- ◆ Length of punch - 100mm.



Part No.	Punch Dia.	Sq. Head
25361	1.5mm	10mm
25362	2.5mm	10mm
25363	3.0mm	10mm
25364	4.0mm	10mm
25365	5.0mm	10mm

Wrecking Bars

- ◆ For opening wooden cases & packing boxes, dismantling wooden crates & pulling out nails.
- ◆ Both ends properly hardened.
- ◆ All wrecking bars come in an attractive powder coated finish.
- ◆ Length measured from bend to chisel point.

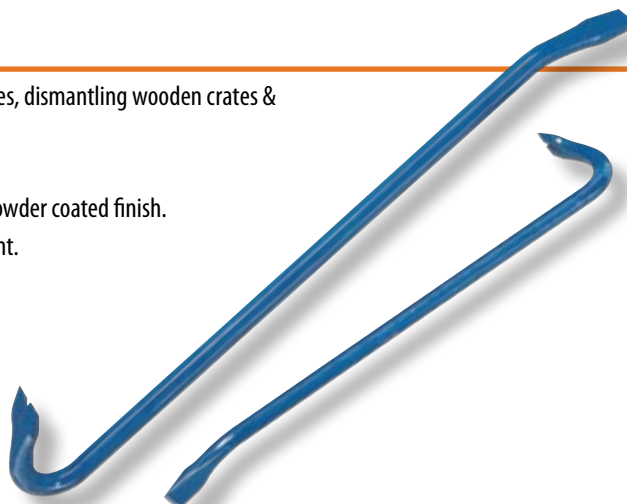

Part No.	Length	Section
33101	400mm	16mm
33104	600mm	19mm
33107	1000mm	19mm

Drill Press Vice - Precision

- ◆ Manufactured from graded cast iron.
- ◆ Base & slides are precision ground for stability & accurate operation.
- ◆ Horizontal and vertical V-groove in the stationary jaw for holding of round job securely.

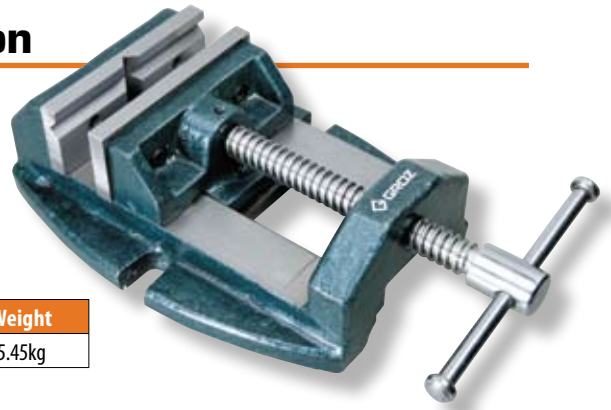

Part No.	Jaw Width	Jaw Opening	Jaw Depth	Weight
35111	100mm	100mm	54mm	5.45kg

Drill Press Vice - Unigrip

- ◆ Manufactured from graded cast iron, these vices have precision ground base & vice bed for smooth movement of movable jaw.
- ◆ Fixed jaw with longitudinal and transversal prisms allows for firm gripping of round jobs.
- ◆ Special jaw seat for retaining flat jobs.
- ◆ Spindle moves inside the hollow hand grip allowing vice to be used away from table edge.

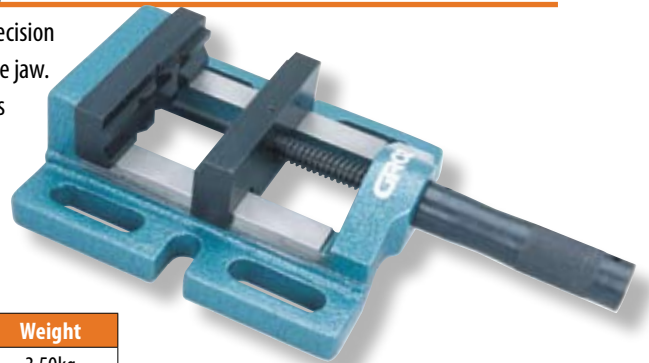

Part No.	Jaw Width	Jaw Opening	Jaw Depth	Weight
35120	75mm	70mm	30mm	3.50kg
35121	100mm	88mm	30mm	4.15kg
35122	125mm	120mm	35mm	7.90kg

3-Way Drill Press Vice – Unigrip

- ◆ This vice allows 3 mounting options via 2 additional precisely ground surfaces: end face and side face.
- ◆ This allows for drilling along all axes with a single setting of the job and holding of long work pieces which are cumbersome and difficult to manage in regular vices.

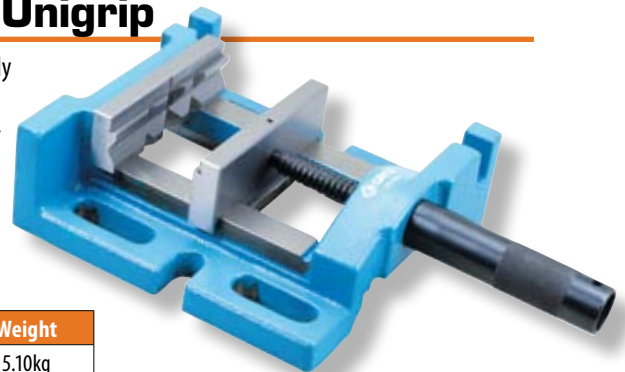

Part No.	Jaw Width	Jaw Opening	Jaw Depth	Weight
35125	100mm	88mm	30mm	5.10kg

T Bar Clamp

- ◆ Robust clamp for applications requiring extra resilience under extreme pressure.
- ◆ These can be fixed to workbench.
- ◆ T bar made from cold drawn steel, malleable iron head & slide.
- ◆ Steel screw has acme threads for smooth movement.



Part No.	Length	Capacity
39100	900mm	750mm
39101	1200mm	1050mm
39102	1500mm	1350mm
39103	1800mm	1650mm

Handyman Hacksaw

- ◆ An adjustable hacksaw frame with outstanding design and superior quality.
- ◆ The rectangular section of the tubular frame ensures perfect combination of rigidity and balance.
- ◆ Aluminium die cast handle provides comfortable grip.
- ◆ The saw is adjustable for 250 – 300 mm blades, the blade cuts at 90° angle and can also be set at 45°.
- ◆ Spare blades can be stored in the hollow tube.

Part No.	Length	Height	Depth of Bow
30010	430mm	130mm	106mm

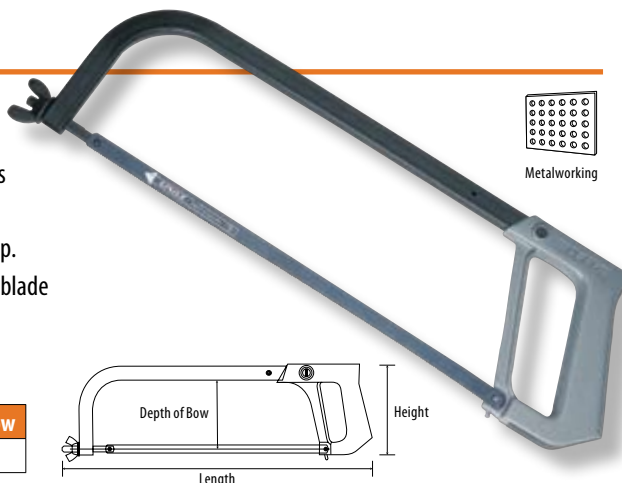

Junior Saw – Baby Bite

- ◆ Professional quality junior saw designed to provide the best means for coping with small sawing applications.
- ◆ Strong steel frame has blade tensioning device along with high quality sturdy plastic handle.
- ◆ Complete with shatterproof blade.
- ◆ Blade size 155 x 6.35 x 0.45mm

Part No.	Length	Height	Depth of Bow
30100	250mm	100mm	50mm



Junior Saw Frame

- ◆ Superior quality powder coated steel wire saw frame designed to ensure correct alignment and allows perfect blade tension during use.
- ◆ Powder coated frame.

Part No.	Length	Height	Depth of Bow
30130	260mm	70mm	60mm

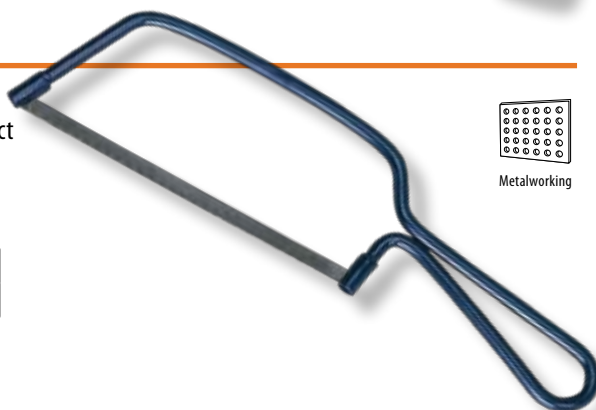

Coping Saw Frame

- ◆ Specially designed for cutting intricate shapes in wood.
- ◆ Blade can be turned to cut at any angle, correct tension being applied by turning handle.
- ◆ Rigid and well balanced frame has wooden handle for comfortable grip.

Part No.	Length	Height	Depth of Bow	Frame
30220	320mm	136mm	125mm	Powder Coated
30221	320mm	136mm	125mm	Chrome Plated

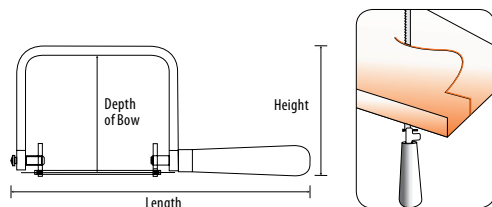

Revolving Punch Pliers

- ◆ An absolute top seller, these professional pliers are made of heavy gauge pressed steel sheet.
- ◆ Punches are accurately heat treated for extended life and are exposed to a brass anvil which prevents the edges from getting damaged in use.
- ◆ Size to be punched can be chosen easily by revolving spring loaded punch holder.
- ◆ Length 220mm

Part No.	Punch Size
31600	2mm, 2.5mm, 3mm, 3.5mm, 4mm & 4.5mm dia.



Tin Snips - General Purpose

- ◆ Dropped forged from chrome vanadium steel.
- ◆ Blades hardened, tempered & precisely ground for extended life.
- ◆ Special design of handle prevents hands from being nipped.

Part No.	Length
32331	250mm
32332	300mm



Lever Grease Gun - Heavy Duty

- ◆ Professional lever action grease gun with heavy duty die cast head.
- ◆ Half/variable stroke feature pumps grease with limited action for use in confined spaces.
- ◆ Black texture non-slip finish.
- ◆ Develops up to 10,000 PSI/690 Bar.
- ◆ For use with 400g grease cartridge.
- ◆ Fitted with bulk loader and air release valve.
- ◆ Rubber grip handle.

Part No.	Cartridge Capacity	Bulk Capacity	Threads
42700	400g	500cm ³	1/8" BSPT

Heavy duty grease gun head incorporates a bulk loader and an air bleeder valve



Unique lock lever allows user to easily lock plunger rod in any position.

Lever Grease Gun - Heavy Duty

- ◆ Professional lever action grease gun with heavy duty die cast head.
- ◆ Half/variable stroke feature pumps grease with limited action for use in confined spaces.
- ◆ Black texture non-slip finish.
- ◆ Develops up to 10,000 PSI/690 Bar.
- ◆ For use with 450g grease cartridge.
- ◆ Fitted with bulk loader and air release valve.
- ◆ Rubber grip handle.

Part No.	Cartridge Capacity	Bulk Capacity	Threads
42780	450g	650cm ³	1/8" BSPT

Heavy duty grease gun head incorporates a bulk loader and an air bleeder valve



Professional 90° Angle Lube Adaptor

- ◆ For greasing inaccessible grease fittings in shoulders and other confined areas.

Part No.	Needle Length	Needle Diameter
44922	53mm (2.09")	10.7mm (0.42")



Ezee Lube Kit

- ◆ Difficult greasing made easy with this range of quick connect lube accessories.
- ◆ Converts any grease gun fitted with a jaw type coupler into special application greasing.
- ◆ This helps in effective lubrication of grease plugs, sealed bearings, push on greasing of recessed fittings or fittings in shoulders or low height areas.

Part No.	Contents
44950	7 Piece Set



Paint Mixers

- ◆ A handy tool for mixing paint to the exact consistency.
- ◆ Fluted construction.
- ◆ Powder coated for rust protection.

Using Paint Mixer

Place paint mixer in the container of material and gently work around the container edges until the material starts flowing towards the centre of the blades.

- ◆ Gently work on the material until it is of desired consistency.
- ◆ For coarse or still materials, reverse the direction of the drill and follow above steps.
- ◆ The mixer works best with a variable speed reversible drill machine with 400 – 600 watts minimum power.
- ◆ Recommended speed between 200 – 700 rpm depending upon the material being mixed.

Important

- ◆ Do not use paint mixer with lacquer or other such inflammable liquids (with flashpoint under 32°C - 70°F).
- ◆ Insert mixer well into the material before turning on the drill.
- ◆ When mixing is complete, wait for the mixer to come to a halt before removing it from the container.

Part No.	Dia. of Mixing Wheel	Length	Fits Drill size
14620	60mm	400mm	3/8"
14621	80mm	400mm	3/8"

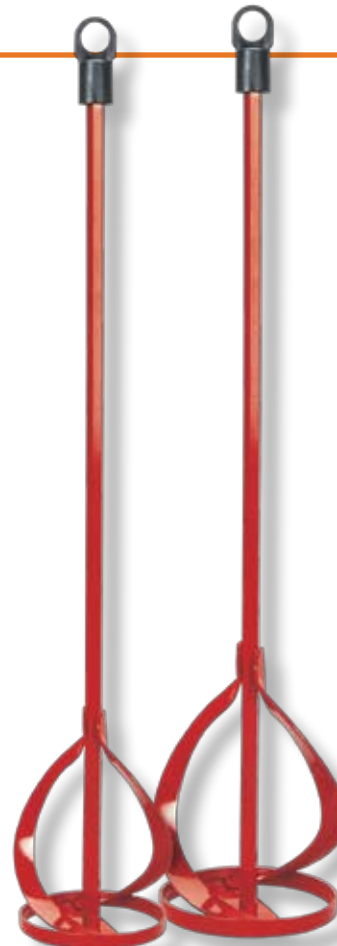

ALPHABETICAL INDEX

	Page
Adjustable Bevel	2
Adjustable Tap & Reamer Wrenches - Bar Type	6
Box Wrenches & Sets	9
Calipers - Brass	4
Calipers - Firm Joint	3
Calipers - Jenny	3
Calipers - Inside & Outside - Quick Nut Type	3
Deburring Tool Holder Set	7
Degree Protractor	4
Depth and Angle Gauge	4
Depth Gauge with Protractor	4
Die Holders (Stocks) for Round Dies	7
Drill Drift Key	6
Drill Sleeves	6
Engineer's Tool Sets	5
Ezee Lube Kit	16
Hand Taps - Carbon Steel	7
Lever Grease Gun - Heavy Duty	15
Paint Mixers	16
Professional 90° Angle Lube Adaptor	16
Punch Sets - Numbers & Letters	5
Punches - Automatic Centre	11
Punches - Hollow & Arch (Leather)	8
Punches - Nail - Square Head	11
Punches - Set of 6 Hollow Punches	8
Punches - Pin Punch Set Long	11
Riveter - Lazy Tong	10
Riveter - Plier Style	10
Revolving Punch Pliers	14
Saw - Coping Frame	13
Saw - Handyman Hacksaw	13
Saw - Junior - Baby Bite	13
Saw - Junior Frame	13
Scriber with Magnet	5
Spring Dividers - Quick Nut Type	3
T Bar Clamp	12
Tap Wrenches - T Handle Type	6
Tin Snips - General Purpose	14
Vee Blocks & Clamp Set - Super Precision	2
Vee Blocks - Cast Iron	2
Vee Blocks & Clamps - Toolmakers	2
Vices - Drill Press	12
Wheel Dressers and Cutters	8
Wrecking Bars	11

PART NO. INDEX

Part No.	Page	Part No.	Page	Part No.	Page	Part No.	Page
01214	4	08424	6	14621	16	32000	9
01216	4	08426	6	25010	11	32001	9
01217	4	08429	6	25361	11	32002	9
01220	4	08430	6	25362	11	32003	9
01221	4	08431	6	25363	11	32004	9
01300	4	08601	6	25364	11	32005	9
01431	3	08602	6	25365	11	32006	9
01432	3	08603	6	25508	11	32007	9
01433	3	08605	6	25902	5	32008	9
01434	3	09102	7	25904	5	32009	9
01435	3	09110	7	25905	5	32010	9
01441	3	09111	7	25906	5	32019	9
01442	3	09112	7	25907	5	32100	9
01443	3	09113	7	25908	5	32101	9
01444	3	09114	7	26102	5	32102	9
01445	3	09200	6	26104	5	32103	9
01451	3	09201	6	26105	5	32104	9
01452	3	09202	6	26106	5	32105	9
01453	3	09203	6	26107	5	32109	9
01454	3	09302	6	26108	5	32200	9
01455	3	09304	6	26305	8	32201	9
01500	3	09320	6	26306	8	32331	14
01502	3	09321	6	26309	8	32332	14
01503	3	09402	7	26310	8	33101	11
01504	3	09404	7	26311	8	33104	11
01505	3	09406	7	26312	8	33107	11
01520	3	09408	7	26314	8	35111	12
01522	3	09409	7	26316	8	35120	12
01523	3	09411	7	26319	8	35121	12
01524	3	09413	7	26320	8	35122	12
01525	3	09415	7	26325	8	35125	12
01540	3	09606	7	26327	8	39100	12
03000	2	09608	7	26329	8	39101	12
03001	2	09610	7	26330	8	39102	12
03002	2	09612	7	26332	8	39103	12
03003	2	09614	7	26333	8	39400	2
03004	2	09616	7	26335	8	42700	15
03080	2	09618	7	26338	8	42780	15
03100	2	09620	7	26391	8	44922	16
03101	2	12070	8	30010	13	44950	16
03106	2	12071	8	30100	13		
03221	5	12072	8	30130	13		
03600	5	12080	8	30220	13		
03601	5	12081	8	30221	13		
08420	6	12082	8	31600	14		
08421	6	12101	7	31650	10		
08423	6	14620	16	31651	10		